



RIM DRIVE TECHNOLOGY



Manual

Entry Level – Outboard tiller

Changes

Version	Date	Changes
1	23-09-2024	Original
2	04-11-2025	Tiller update
3	03-06-2026	Remove conversion section

Declaration of Conformity

Company name manufacturer	Rim Drive Technology
Company address manufacturer	Wanraaij 4 6673 DN Andelst The Netherlands
Product type	EL Outboard system

Foreword

Dear customer,

We are delighted by the choice for our products. Our outboard systems delivers high-performance by using rim drive technology and is highly efficient. These motors are perfect candidates for those who want to sail electric, as they have a streamlined design, are sustainable and functional. It has been designed and manufactured with an eye on convenience, environment friendly character, user-friendliness and safety. Before shipment, every motor is tested extensively by our test engineers.

Please take the time to read this operating manual carefully as to ensure safe and proper use of the outboard motor. It is always our intention to improve RDT products, for any feedback please do not hesitate to contact us.

Please feel free to contact us with any product inquiries. We wish you all the best with our products.

Rim Drive Technology

Content

Changes.....	2
Declaration of Conformity	2
Foreword.....	3
1. General.....	6
1.1 Using this user manual	6
1.2 Pictograms	6
1.3 Copyright	6
1.4 Ensure	7
1.5 Manufacturer details.....	7
2. Security.....	8
2.1 Appropriate use	8
2.2 Requirements for operators.....	8
2.3 Safety	9
2.4. Personal Protective Equipment	10
2.5 Maintenance/fault removal.....	10
3. Technical data	11
3.1 General data	11
4. Mounting.....	12
4.1 General Installation	12
4.2 Tiller Installation/Removal.....	13
5. Description	15
5.1 General	15
5.2. Outboard Construction.....	15
5.2 Tiller Construction	16
5.3 Tiller User Interface	16
6. Installation	17
6.1 Hardware	17
6.1.1 Motor controller	17
6.1.2 Fuses	17
6.2 Software.....	17
6.3 Batteries.....	17
7. Operation	18
7.1 Preparation	18
7.2 Operation.....	18
7.3 Stop operation	18
7.4 Use frequently	18
8. Maintenance & cleaning	19

8.1 Maintenance.....	19
8.1.1 Replacement parts.....	20
8.1.2 Corrosion protection	20
8.2 Cleaning	20
8.3 Dismounting.....	21
9. Service	22
9.1 Service activities	22
9.2. Registration service claim.....	25
10. Disorders	27
10.1 Possible disorders	27
10.2 Error codes.....	28
11. Disposal and environment	29
11.1 Disposal of waste electrical and electronic equipment.....	29
11.2 Disposal of batteries	29
12. General conditions for warranty.....	30
12.1 Warranty and liability	30
12.2 Scope of warranty.....	30
12.3 Warranty process	31
12.4 Shipment.....	31

1. General

1.1 Using this user manual

Every person who is operating, servicing, maintaining or using the RDT outboard must have read and understood this manual in detail. The manual provides important instructions for the safe and proper use of the RDT outboard. After reading this user manual the owner/operator should have an understanding on how to

- Install the product
- Operate the product
- Avoid risks/hazards

Always store this manual close to the RDT outboard. We advise to store the manual in a waterproof sealing.

The illustrations in this manual are for illustrative purposes only and are not relevant to the design details of the RDT outboard.

1.2 Pictograms

The following pictograms are used in this manual:



Dangerous situation. If this warning is ignored, personal injury up to death or serious damage to the RDT outboard may result.



Danger due to electric current. The work may only be carried out by a trained electrician



Danger of possible damage to the environment.



Note of useful advice on how to use the RDT outboard.

1.3 Copyright

This is a confidential user manual. All documents are protected within the meaning of the Copy-right Act.

Disclosure and duplication of documents, including extracts, exploitation and communication of their contents are not permitted. Violations are punishable and oblige to pay damages. We reserve all rights of exercise of industrial property rights.

1.4 Ensure

For safe and pleasant operation and use of the EL Outboard rim drive, it is recommended to read this manual in full before installing or commissioning the RDT EL Outboard. The manufacturer is not liable for damages or improper functioning of the RDT EL Outboard as a result from failing to adhere to the operating instructions.

Additionally, please read/check the national regulations before the use of the RDT outboard. The warranty expires, for example, in the case of:

- Usage for any other application than intended by the manufacturer or beyond the applications as described within this manual.
- Installation not in accordance with the manual
- Use of non-original spare parts and complementary products
- Maintenance/servicing by a non-authorized persons/company.
- Operating RDT outboard outside the water
- Damage caused by journeys through overgrown waters (e.g. reeds) or too shallow waters.

1.5 Manufacturer details

Rim Drive Technology BV

Wanraaij 4
6673 DN
Andelst
The Netherlands

+31 (0) 85 482 48 55

info@rimdrivetechology.nl

www.rimdrivetechology.nl

2. Security

2.1 Appropriate use

In order to provide customers the perfect fit for their application we realized highly configurable products which can be used for the following applications: Leisure marine, commercial marine, unmanned surface vessel (UAV), and subsea. Any other type of application is not allowed without written permission from RDT.

Only power sources which have been approved by RDT should be used in combination with the RDT products.



Danger of destruction! When operating outside the water the RDT outboard will be destroyed. Operate the RDT outboard only in water.

The intended use also includes people who are servicing/maintaining or operating the RDT outboard and must have read and understood this user manual. All procedures described in this user manual must be followed.

The manufacturer is not responsible for damages resulting from operation in a way which is not in accordance with this manual. The risk is exclusively for the user/operator.

2.2 Requirements for operators

Only persons who have the right licenses (according to national law) may use the RDT rim drive as a boat drive.



The required qualification can be found in the applicable national regulations and laws of the country in which the boat is used.

Repair work, follow-up and maintenance/service may only be carried out by persons with the appropriate training and qualifications by Rim Drive Technology.

Persons under the influence of drugs, alcohol or reacting drugs are not allowed to carry out work on the RDT outboard or to operate it.

2.3 Safety

In addition to the information in this manual, observe the general legal and other binding regulations for accident prevention and environmental protection as well as basic health and safety regulations.

- Check if the RDT EL Outboard is in perfect condition before operating
- Turn on the RDT EL Outboard only when the rim drive is placed completely in water. This is the only way to avoid damage to the RDT EL Outboard rim drive.
- Never remove or change safety devices.
- Before use always inspect the RDT EL Outboard for (external) recognizable damage and defects. If any damage and/or defects are recognized they must be reported immediately to a RDT qualified service partner.
- Use only professional and qualified maintenance tools.
- After repairs/maintenance, reattach all dismantled protective devices and ensure proper functioning.
- Every operator is responsible to make sure that the RDT EL Outboard is only operated in perfect/non-damaged condition and that all applicable safety requirements and regulations are complied with.
- Never allow the boat to which the rim drive is mounted to be towed when the system is turned off. Keep the system on, or remove the motor from the water before towing.
- Never operate the tiller without having the dead mans cord attached to the operator.

2.4. Personal Protective Equipment

Personal Protection Equipment

Personal Protective Equipment (PPE) is important because it protects workers from injuries and accidents. They ensure that employees can work safely. It is therefore important that employees use the correct personal protective equipment and maintain it correctly.

The need for PPEs is well proven and critical to your safety and practically mandatory when servicing a rim drive product. Always check local PPE requirements before boarding a vessel and/or commencing service.

As a Rim Drive Technology service engineer your PPE's should be:

- Be in compliance with our work instructions
- Be suitable with any other equipment you use at the same time
- Be appropriate for the risks involved, and the task being performed, without itself leading to any significant increased risk (e.g. using gloves, hearing protectors, safety glasses..).
- Ensure that you always work with safe and approved resources such as machines, tools and devices.
- Take responsibility to stop unsafe activities and to intervene in unsafe situations.

What PPE's are recommended to bring when working with rim drive product?

- Eye protection (e.g. safety glasses)
- Ear plugs or hearing protection
- Proper fitting working cloths
- Life jacket / drowning protection (e.g. working outboard).
- Safety gloves (suitable for working with oil/glue)
- Safety shoes (toe cap and anti-slip)
- Other PPE's locally required

2.5 Maintenance/fault removal

Check the deadlines for regular inspections specified in the user manual.

Use only the professional/qualified tools for maintenance/fault removal.



Danger from electric current! Incorrect work on the power supply may result in damage to the RDT outboard. Work on the electrical equipment of the RDT outboard may only be carried out by a certified electrician.

3. Technical data

3.1 General data

Model	EL Outboard	EL Outboard	EL Outboard	EL Outboard	EL Outboard	EL Outboard	EL Outboard
Type	2.5	3.0	4.2	5.0	8.0	11.0	15.0
Input voltage	24	48	24	48	48	48	48
Nominal power	2.5	3.0	4.2	5.0	8.0	11.0	15.0
Maximum RPM	3.200	4.000	1.750	2.500	2.000	1.500	1.700
Maximum temp.	85°C	85°C	85°C	85°C	85°C	85°C	85°C
Temp. sensor	PT1000	PT1000	PT1000	PT1000	PT1000	PT1000	PT1000
Maximum depth*	5 meters	5 meters	5 meters	5 meters	5 meters	5 meters	5 meters
Motor controller	48V 250A	48V 250A	48V 600A	48V 250A	48V 450A	48V 600A	48V 600A
Length mc	160 mm	160 mm	250 mm	160 mm	200 mm	250 mm	250 mm
Width mc	200 mm	200 mm	200 mm	200 mm	200 mm	200 mm	200 mm
Height mc	72 mm	72 mm	72 mm	72 mm	72 mm	72 mm	72 mm
Weight mc	3.25 kg	3.25 kg	4.9 kg	3.25 kg	4.1 kg	4.9 kg	4.9 kg

4. Mounting

4.1 General Installation

Before mounting the outboard motor to the boat transom:

- Ensure the transom plate is free from defects
- Verify the transom plate is strong enough to handle the motor torque / power. Due to the rim drive motor design, the motor will have access to instant full torque.
- Ensure the transom plate will fit the outboard bracket with the mounting bolts fully opened.

After performing these checks, the outboard system can be installed using the installed mounting bolts. Tighten the mounting bolts until the outboard bracket is securely attached to the transom plate. Check this before and after.

4.2 Remote steering Installation

If you have the tiller version, refer to chapter 4.3 Tiller Module Installation/Removal

Next mount the steering system to the installed bracket. Several options are possible such as mechanical or hydraulic steering systems. If you are unsure if the selected system will work with the outboard motor, please contact your dealer or RDT, Please see the system construction for all component descriptions.

The system has been carefully designed to enable the use of hydraulic steering cylinders. These cylinders can be threaded onto the included 7/8-14" threaded rod.

We recommend the steering cylinder outboard type: HC4645-3. After mounting the cylinder can be connected to the steering adapter. With the cylinder mounted, please follow the cylinder manual to check the installation and verify the system is correctly assembled.

The steering adapter allows for use of mechanical steering systems, please follow the provided steering system manual for correct installation.

With the steering system correctly installed, the maximum rotation should be checked to ensure proper clearance. Furthermore, ensure the included cable hose is free from the chance of damage or kinking.



Please note the motor controller will need to be mounted externally from the EL Outboard. See the installation notes, wiring diagram and motor controller manual for more detailed information.



Danger of broken motor! When the motor is not installed in the right way there is risk for a broken motor.

4.3 Tiller Module Installation/Removal

The installation and removal of the tiller module is done by pressing the spring loaded shaft(circle in green in Figure 1) on the tiller mounting bracket with following steps.

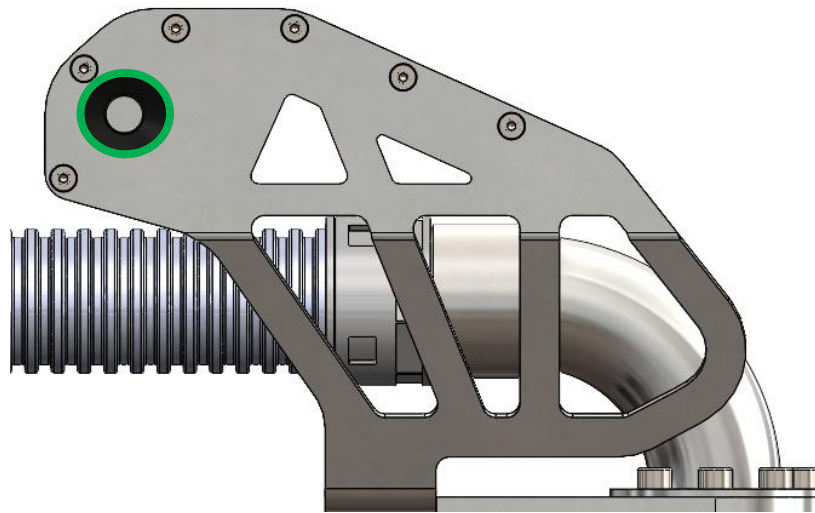

Figure 1 Shaft for instal/remove the tiller module

1. Push the shaft to adjust its position, at the correct position the shaft exposed from the bracket module (circle in green in Figure 2), should be thinner compared to neutral position.

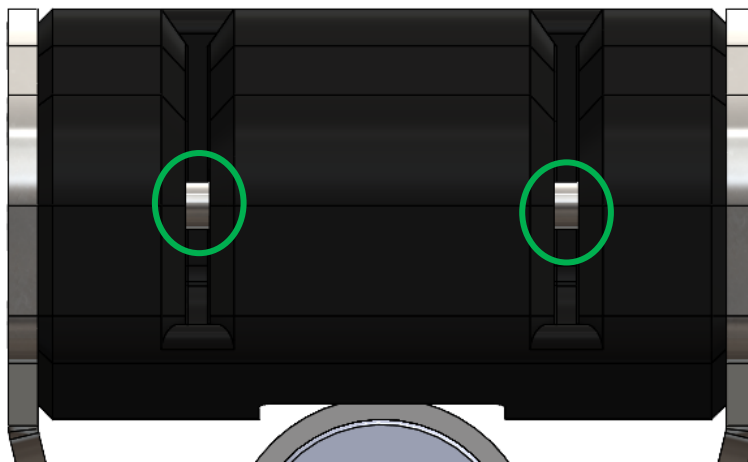

Figure 2 Shaft neutral position

2. Keep the shaft pressed in when mounting the tiller module. The position can be seen in Figure 3 Mounting the tiller module. If the module is not able to be inserted, go back to step 1 make sure the shaft is in the correct position.

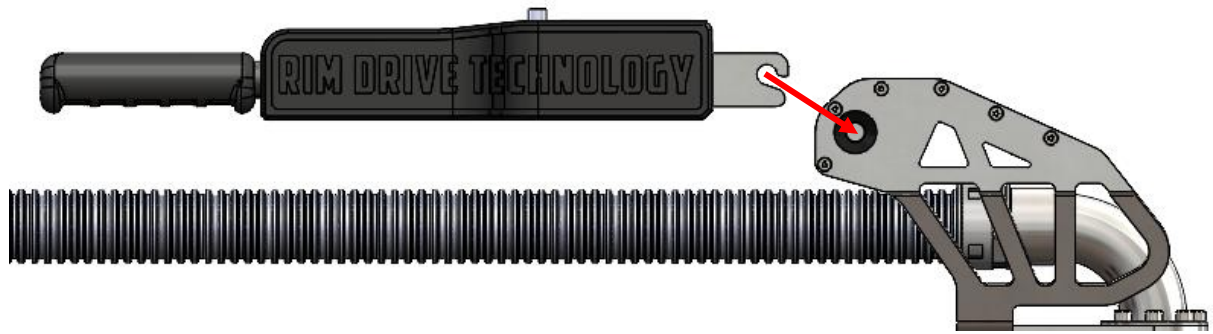

Figure 3 Mounting the tiller module

3. Once the tiller module has been mounted, release the shaft, the shaft should return to its neutral position and keep the tiller module locked in place. If not, then adjust the position of the tiller and push the shaft back to its neutral position.
4. Move the tiller module make sure it is fully locked by the shaft (if not go back to step 3 to adjust the tiller's position), then the installation of the tiller module is finished.



When removing the tiller module, just follow the same procedure but invert the steps.

4.4 Tiller Module Wiring Setup

In order to operate the system several connections have to be made after installing the tiller. The most important ones are the throttle and Kill switch. In order to connect the throttle, look for the 3-pin connector labeled throttle and connect this to the 3-pin marked throttle already installed on the vessel. For the kill switch, find the two slide on connectors, connect these to the kill switch poles.

Next connect the display, depending on the configuration this might be different. For all three configurations connect the motor controller CAN to the Small M8 port

Type 1 Motor controller + RDT battery

Connect the battery to the M12 port with the cable marked battery CAN

Type 2 Motor controller + Shunt

Connect the NM cable from the bus to the display M12 port.

Type 3 Motor controller + NG RDT Battery

Connect the Battery Serial cable to the serial port.

5. Description

5.1 General

The RDT EL Outboard system is a propulsion system for leisure boats. The installation location is normally at the stern of the boat on the transom. Other installation locations can be selected as long as the mounting is secure and follows this manual. In case of any questions, please contact a RDT or a RDT qualified service center.

The RDT EL Outboard systems have been designed in such a way that the power supply can be provided by generators or battery packs.

5.2. Outboard Construction

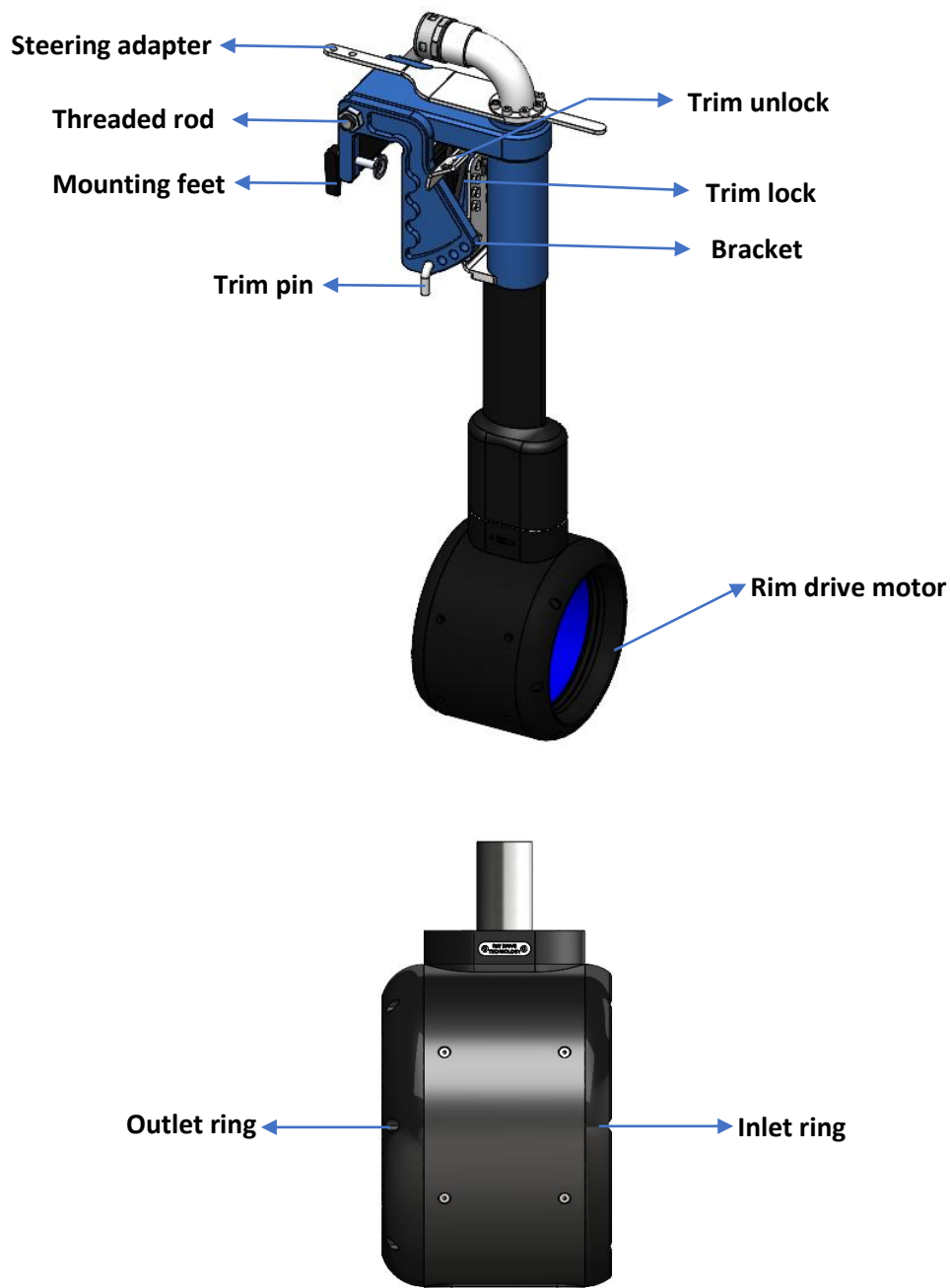

A sticker is connected to each system, it records the key data as per the EC machinery directive 2006/42/EC.

5.2 Tiller Construction

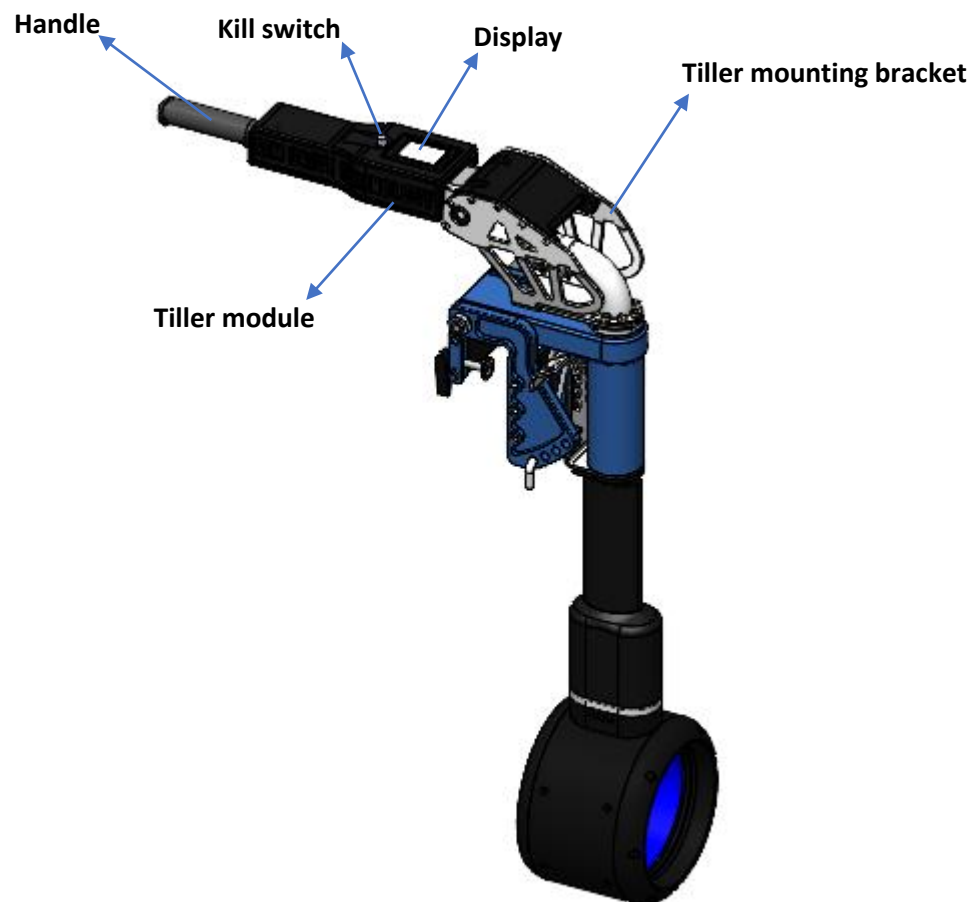

5.3 Tiller User Interface

For the interface of the tiller, please follow the manual of the EL Display for guidance and more operating information.

6. Installation

6.1 Hardware

For the installation always refer to a professional and trained company. The outboard system, batteries, throttle controls and other products shall only be installed as described by Rim Drive Technology.

No client, installation company, dealer or any other person/company is allowed to make any changes to the hardware/software.

All safety equipment like kill switches, fuses, relays, other type of safety products should be installed by a professional and trained company according regulation/law for the country within which the products are used.

When verifying the correct operation of the motor, ensure all accessible DC connections are checked immediately after reaching full power. When performing this check directly after full power is applied, all connections should not be warm to the touch. If connections are hot to the touch, please reinstall the DC connections.

After 10 and after 50 hours of running the motor the mounting bolts have to be checked.

6.1.1 Motor controller

Depending on the choice of motor controller, a wiring schematic should be followed. Always contact RDT for the manual of the motor controller. The motor controller should be connected using shielded cables which are preferably located in stainless steel or aluminum tubing.

6.1.2 Fuses

To ensure a safe system several fuse(s) have to be installed. RDT is not responsible for damage occurred by fuses which were not delivered by RDT.

6.2 Software

Rim Drive Technology will provide software which is developed for the specified configuration. Nobody is allowed to make any changes to the software, except Rim Drive Technology.

6.3 Batteries

The motors could additionally be used as a generator. Make sure that the used configuration is suitable for this purpose. A reverse voltage can be applied to the system which might require consideration in certain applications.

7. Operation

7.1 Preparation

Ensure the following preparations have been carried out before operating the RDT products.

Unplug the cable/plug from the power supply.

Store the charging cable in a way which as to prevent damage or tripping.

Check the remaining capacity of the batteries.



Do not put the RDT rim drive into operation if the remaining battery capacity is < 20%

7.2 Operation

Ensure the following preparations have been carried out before operating:

- Plug in the power supply for the RDT outboard.
- Ensure the motor can be put forwards and backwards without noise etc.
- Regularly check the remaining battery capacity during operation. Otherwise there is a risk of having no propulsion.

7.3 Stop operation

Ensure the following actions have been carried out when stopping the use of the RDT rim drive:

- Disconnect the power supply for the RDT outboard.
- Connect the charging cable to the charger.
- Make sure that the charging cables are placed in a safe way as to prevent tripping or accidental damage.



Lay down the charging cable as to prevent damage.

7.4 Use frequently

The motor has to be used for a minimum of five hours every month.

8. Maintenance & cleaning

8.1 Maintenance

Have the RDT outboard checked at least once a year by Rim Drive Technology or by an authorized specialist to check for perfect condition. If damage is discovered, it must be rectified immediately by a RDT service partner before operating. Do not use the RDT product when it is damaged.



Danger of destruction! Maintenance should only be performed by authorized personal/ service centers. Otherwise, errors may occur which can lead to the destruction of the rim drive. Rim Drive Technology accepts no liability for damages caused by improper maintenance.

Maintenance level	Executor	Working hours	Time
Maintenance level 1	Client	5 hours	Every run
Maintenance level 2	Client	100 hours	One year
Maintenance level 3	RDT Service partner	1.000 hours	Five years

Service task	Level 1	Level 2	Level 3
Test functionality	Propeller turns forward Propeller turns reverse Motor is reacting fast		
Cable connections		Check for damage Visual check Check connectors	
Batteries and cables		Visual check of cables Visual check of connectors Visual check of connections	
Anode		Replacement	
Mechanical connection to hull		Test and repair if necessary	
Waterproofness			Visual check of complete motor
Full product test			Control propeller quality

*The client is responsible to contact a RDT authorized service center for maintenance level 3.

8.1.1 Replacement parts

For information on spare parts and the installation of these parts, contact Rim Drive Technology or an authorized Service Partner. Only RDT spare parts may be used.

8.1.2 Corrosion protection

A high level of corrosion resistance is ensured by the design of the products and with the selection of the materials. All materials are classified as sea water resistant materials.

To reduce the chance of corrosion:

- Check the anode latest every 6 months. Change the anode every 12 months or after >50% of anode has been destroyed by environment.
- Regularly apply a suitable contact spray (e.g. Wet protect) to cable contacts, data sockets, and data plugs.
- The use of anti-fouling agent is forbidden.
- Only mount original RDT anodes to the rim drive motor. Otherwise no guarantees can be given.
- In different operation cases, different types of anode is applied as shown in table below.

Operation case	Anode material
In salt water/sea water environment	Zinc
In fresh water environment	Magnesium
In brackish water environment	Magnesium
In case the motor is being used in different water types	Magnesium

In standard each motor is delivered with a magnesium anode.

8.2 Cleaning

Before starting turn off the power supply, as to prevent accidental activation during the cleaning process.



Injury! When the power supply is switched on, the rim drive may cause injuries to the limbs when cleaning the RDT rim drive.

The cleaning intervals depend on the area of application and the number of operating hours. At least, the rim drive must be cleaned once a year in fresh water.

In case of contaminated, salt water or with frequent use of the rim drive; the interval between cleaning should be shortened.



Only use fresh water for cleaning.

8.3 Dismounting

The client is not allowed to dismount, remove or disassemble any parts from the products. Examples of activities which are not allowed without written approval:

- Removal of mounting rings with bearings
- Removal of rotor housing
- Removal of cables
- Removal of mounting socket
- Removal of covers

9. Service

9.1 Service activities

Video instructions on the various service activities can be found in the digital training platform for our distributors.

Replacing a propeller

Motor	Bolt type *	Allen wrench	Points of attention
2.5 / 3.0kW	DIN 7991 M4x8	2.5	- Torque wrench: 1.5Nm - Use TIKAL TEFGEL
4.2 / 5.0kW	DIN 7991 M5x8	3	- Torque wrench: 2.5Nm - Use TIKAL TEFGEL
8.0kW	DIN 7991 M5x12	3	- Torque wrench: 2.5Nm - Use TIKAL TEFGEL
11.0kW	DIN 7991 M5x12	3	- Torque wrench: 2.5Nm - Use TIKAL TEFGEL
15.0kW	DIN 7991 M5x12	3	- Torque wrench: 2.5Nm - Use TIKAL TEFGEL

* Stainless steel 316

Installing mounting rings**

Motor	Bolt type*	Allen wrench	Points of attention
2.5 / 3.0kW	DIN 7991 M3x20	2	<ul style="list-style-type: none"> - Torque wrench: 0.75 Nm - Check that the rotor bearings are straight in the mounting ring bearings before tightening the bolts. - Use TIKAL TEFGEL
4.2 / 5.0kW	DIN 7991 M4x20	2.5	<ul style="list-style-type: none"> - Torque wrench: 1.5Nm - Check that the rotor bearings are straight in the mounting ring bearings before tightening the bolts. - Use TIKAL TEFGEL
8.0kW	DIN 7991 M5x20	3	<ul style="list-style-type: none"> - Torque wrench: 2.5Nm - Check that the rotor bearings are straight in the mounting ring bearings before tightening the bolts. - Use TIKAL TEFGEL
11.0kW	DIN 7991 M5x20	3	<ul style="list-style-type: none"> - Torque wrench: 2.5Nm - Check that the rotor bearings are straight in the mounting ring bearings before tightening the bolts. - Use TIKAL TEFGEL
15.0kW	DIN 7991 M5x20	3	<ul style="list-style-type: none"> - Torque wrench: 2.5Nm - Check that the rotor bearings are straight in the mounting ring bearings before tightening the bolts. - Use TIKAL TEFGEL

* Stainless steel 316

**This part should only be done by a provided service centre.

Replacing inlet / outlet ring

Motor	Bolt type*	Allen wrench	Points of attention
2.5 / 3.0kW	DIN 912 M3x25	2.5	- Torque wrench: 1.5 Nm - Use TIKAL TEFGEL
4.2 / 5.0kW	DIN 912 M4x25	3	- Torque wrench: 1.5Nm - Use TIKAL TEFGEL
8.0kW	DIN 912 M5x25	3	- Torque wrench: 5Nm - Use TIKAL TEFGEL
11.0kW	DIN 912 M5x25	4	- Torque wrench: 5Nm - Use TIKAL TEFGEL
15.0kW	DIN 912 M5x25	4	- Torque wrench: 5Nm - Use TIKAL TEFGEL

* Stainless steel 316

Replacing anode

Motor	Bolt type*	Allen wrench	Points of attention
2.5 / 3.0kW	DIN 7991 M4x16	2.5	- Torque wrench: 0.75 Nm - Use TIKAL TEFGEL
4.2 / 5.0kW	DIN 7991 M4x20	2.5	- Torque wrench: 1.5Nm - Use TIKAL TEFGEL
8.0kW	DIN 7991 M5x20	3	- Torque wrench: 2.5Nm - Use TIKAL TEFGEL
11.0kW	DIN 7991 M5x20	3	- Torque wrench: 2.5Nm - Use TIKAL TEFGEL
15.0kW	DIN 7991 M5x16	3	- Torque wrench: 2.5 Nm - Use TIKAL TEFGEL
15.0k - F	DIN 7991 M5x20	3	- Torque wrench: 2.5 Nm - Use TIKAL TEFGEL

* Stainless steel 316

9.2. Registration service claim

It is important for us that we meet your expectations. Each product has been produced and tested intensively before shipment to worldwide clients. If nevertheless a warranty claim should occur, it will be assessed with the aim of resolving the claim in a timely and effective manner.

For a flawless process we need your cooperation:

- Please complete this registration service claim form.
- Please provide a copy of your proof of purchase (invoice).
- Please send this form to: sales@rimdrivetechology.nl
- Please understand that we have to reject received products which the company was not notified of.
- Please ensure suitable, protected packaging.
- Please be advised that lithium batteries are designated as Dangerous Material. The dispatch of the battery with a transport company has to be organized according to the formalities for dangerous goods and packed in the original packaging.
- Please observe the warranty conditions as listed in the User Manual chapter 12.

Registration service claim

Contact details

First Name:	Last name:
Address:	City, State, Zip Code / Postcode:
Country:	E-mail:
Telephone No.	Mobile No.
When existing: Customer ID	

Details of claim

Exact product name:	Article no.	Serial no.
Date of purchase:	Hours of use:	
Dealer where product was purchased:	Address of dealer: (City, State, Zip Code / Postcode, Country)	
Detailed description of problem (including error message)		
Description of the products of the system that are included:		

10. Disorders

10.1 Possible disorders

Make sure that the power supply is switched off and is secured against activation.



Injury! When the power supply is switched on the rim drive may cause injuries to the user.

Disorder	Possible cause	Fix
The rim drive is not running.	The main switch is not turned on.	Turn on the main switch.
	The batteries are empty.	Charge the batteries.
	The propeller is blocked.	Check if the propeller is damaged.
	Connection/Wiring is not correct/bad.	Check wiring and connections.
	The motor controller gives an error.	Restart the system
	System does not turn on	Check the deadman switch is correctly enabled
The batteries are not charging.	The plug from the charging cable is not properly plugged into the land-side power supply.	Insert the plug correctly into the land-side power supply.
	The land-side power supply is switched off.	Turn on the land-side power supply.
	The batteries are defect.	Replace the defect batteries.

10.2 Error codes

The following table describe all the error codes that the controller will display. The presence of an error can be detected by means of a red led flashing on controller (number of flashes correspond to base error code). The error codes are divided in four different categories, based upon the severity of the faults.

Base fault Code	Description
Controller warning faults – Reduces only performance – Fault will reset itself (if possible)	
0	No error
1	N/A
2	Voltage getting low
3	Inhibit drive/ BDI Cut / BLC via scan
4	Voltage getting high
5	Motor temperature high
6	Controller temperature high
7	Adjustment out of range
8	Default adjustment used
Drive error faults – Commences graceful neutral brake – Requires a neutral recycle action to reset fault	
9	Memory chip fault
10	Both forward and reverse inputs active
11	Ride-on: Seat switch not closed or timed out. Walkie: Tiller switch not closed
12	Power up sequence fault
13	Accelerator more than 50% at power up
14	Inching sequence faults
Soft error faults – Immediately stops pulsing – Requires a neutral recycle action to reset fault	
15	Supply voltage fault
16	N/A
17	Battery voltage too low
18	High sided mosfets short circuit
19	Motor stall protection

Hard error faults – immediately stops pulsing and open line contactor – Reset only by a key switch recycle	
20	Hardware over current detected
21	Contactor coil driver fault (e.g. short circuit)
22	Voltage is too high
23	Low sided mosfets short circuit in neutral
24	Hardware fail safe fault
25	Line contactor (e.g. short circuit)
26	Thermal shutdown fault (only for minimum pump speed fault)
27	Low sided mosfets short circuit during power up and before line contactor is closed.
28	Wire off detected
29	CAN node fault
30	Motor over speeding
31	Motor fault
32	Motor Module initialization error
33	Motor Module configuration inconsistency
34	Motor Module parameter inconsistency
35	Current sensor calibration fault
36	Controller temperature over 100 degree
39	Generic time out
40	System fault

1 1. Disposal and environment

1 1.1 Disposal of waste electrical and electronic equipment

For customers in EU countries

RDT permits all clients to follow the European Directive 2012/19/EU relating to Waste Electrical and Electronic Equipment – WEEE, and to the corresponding national laws. The WEEE Directive forms the basis for handling waste electrical equipment across the whole of the EU. The RDT system is marked with the symbol of a crossed-out rubbish bin. Waste electrical and electronic equipment must not be disposed of as normal household waste, because this could allow entry of pollutants to the environment which have effects injurious to health on humans, animals, and plants, and which build up in the food chain and in the environment. In addition, valuable raw materials are lost in this way. Please therefore direct all waste equipment for separate collection in an environmentally friendly way.



For customers in other countries

RDT permits all clients to follow the European directive 2012/19/EU regarding waste electrical and electronic equipment. We recommend that the system is not discarded as normal household waste, rather this should be disposed of via separate collection in an environmentally friendly way. The applicable national laws may also prescribe this. Therefore, please ensure appropriate disposal of the system as per the regulations which apply in the country within which the rim drive is used.

1 1.2 Disposal of batteries

Remove spent batteries immediately, and comply with the following specific disposal information relating to batteries or battery systems:

For customers in EU countries

RDT permits all clients to follow the European directive 2006/66/EC regarding (spent) batteries, as well as to the corresponding national laws. Here the Battery Directive forms the basis for handling batteries throughout the EU. Our batteries are marked with the symbol of a crossed-out rubbish bin. Spent batteries must not be disposed of as normal household waste, because this could allow pollutants to enter the environment which could have effects injurious to health on humans, animals, and plants, and which build up in the food chain and in the environment. In addition, valuable raw materials are lost in this way. Please therefore dispose of the spent batteries exclusively via specially set-up collection points, the dealer, or the manufacturer. There is no charge for handing them in.

For customers in other countries

RDT permits all clients to follow the European directive 2006/66/EC regarding (spent) batteries. The batteries are marked with the symbol of a crossed-out rubbish bin. We recommend that the batteries are not discarded as normal household waste, rather this should be disposed of via separate collection. Your national laws may also prescribe this. Therefore, please ensure appropriate disposal of the batteries as per the regulations which apply in the country within which the rim drive is used.

12. General conditions for warranty

12.1 Warranty and liability

The statutory warranty runs for and includes all components of the RDT system. The client needs to activate the warranty within 30 days after delivery via our website: www.rimdrivetechology.nl

The warranty period starts from the day of delivery of the RDT system to the end customer.

12.2 Scope of warranty

Rim Drive Technology, Wanraaij 4, 6673 DN, Andelst guarantees the end customer of a RDT system, the product is free from material and manufacturing defects during the period of coverage defined below. Rim Drive Technology will indemnify the end customer for the costs of correction of a material or manufacturing defect. This indemnification obligation does not apply to any incidental costs caused by a warranty case or to any other financial detriment (e.g. costs for towing, telecommunication, accommodation, subsistence, loss of use, lost time, etc.).

The warranty terminates two years from the day of handover of the product to the end customer. Products used - even temporarily - for professional or official purposes are excluded from the two-year warranty. For these uses, the statutory warranty applies. The guarantee claim expires six months after the discovery of the defect.

Rim Drive Technology decides whether defective parts are repaired or replaced. Distributors and dealers who carry out repair work on Rim Drive Technology motors have no power to make legally binding statements on behalf of Rim Drive Technology.

Wearing parts and routine maintenance are excluded from the warranty.

Rim Drive Technology has the right to refuse warranty claims if:

- The warranty was not submitted correctly (especially failure to make contact before dispatching goods under complaint, absence of a fully completed warranty form and of proof of purchase; see warranty process).
- The product has been used in a manner contrary to instructions.
- The safety, operating, and care information in the instructions were not followed.
- Prescribed maintenance intervals were not complied with and documented.
- The purchased item was in any way converted, modified, or equipped with parts or accessory items which are not expressly authorized by Rim Drive Technology or which do not form part of recommended equipment.
- Previous maintenance or repairs were undertaken by companies not authorized by Rim Drive Technology, or parts other than original replacement parts were used. This applies unless the end customer can prove that the circumstances resulting in the refusal of the warranty claim have not encouraged the progress of the defect.
- The product has been used for other applications as described.

In addition to the claims arising from this warranty, the end customer has statutory warranty rights arising from his purchase contract with the relevant dealer; these are not restricted by this warranty.

12.3 Warranty process

It is a prerequisite that the warranty process described below is followed for the fulfilment of warranty claims.

For the problem-free handling of warranty cases, we request that the following instructions are complied with:

- In the event of a claim, please contact Rim Drive Technology. RDT will provide a return number.
- Should it be necessary to transport products to Rim Drive Technology premises, please note that inappropriate transport is not covered by guarantee or warranty.

For queries regarding the warranty process, we can be contacted by means of the details given in this manual.

12.4 Shipment

The client is responsible for shipment, costs and any damage or loss which are related to this shipment.

RIM DRIVE TECHNOLOGY

**Uncompromised
Electric Motors**

www.rimdrivetechology.nl
+31 (0) 85 482 48 55
Info@rimdrivetechology.nl