



**RIM DRIVE TECHNOLOGY**

**RD SKS Bried Installation and Operator  
Manual**

Ref: RD-SKS-IOM-09



## Contents

Overview .....	2
System components .....	2
System Block Diagram .....	3
Mechanical Installation .....	3
RD SKS Control Helm Joystick Installation: .....	3
System Status LED Panel Installation: .....	4
RD SKS Control Box Installation: .....	4
Electrical Installation .....	5
RD SKS Control Box Port Description .....	6
Data for positioning System: .....	8
Connecting to thrusters:.....	8
Operator Manual.....	9
System Operation Steps: .....	12
LED Combinations and system states: .....	14
Error Codes:.....	16
System Configuration:.....	17
Connecting PC to control box:.....	18
Start the System Tuning and Configuration Tool: .....	18
Enter Vessel Configuration Parameters:.....	18
Controller Tuning:.....	20
Heading Controller:.....	20
Position Controller: .....	21
Tuning Process:.....	22
Diagnostics: .....	22
Notes:.....	22





## Overview

Rim Drive’s SKS (Station Keeping System) compliments Rim Drive’s drive by wire controls by enabling the vessel to perform automated behaviors. The SKS primarily consists of a control joystick and a control box. Furthermore, it allows users to add multiple control helms and directly interfaces with advanced remote monitoring solutions.

## System components

The following components are included in each RD-SKS kit.

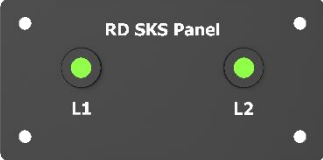
Component	Photo
RD SKS Control Box	
SKS Joystick	
System Status LED Panel	
Network & Setup Cable	M12, X-Code, 8 pin Male to RJ45
Main Helm Station Cable	M12, A-Code, 8 pin Female to free end
SKS Joystick Cable	M12, A-Code, 5 pin female to 5 pin female
Power Cable	M12, A-Code, 8 pin female to free end
RD Network Cable	M12, A-Code, 5 pin female to free end



# System Block Diagram



Figure 1: System Block Diagram

## Mechanical Installation

### RD SKS Control Helm Joystick Installation:

Position and install the *RD SKS Control Helm Joystick* on the dashboard in a location that provides unobstructed and ergonomically convenient access. Where practicable, mount the joystick on a horizontal surface and in a zone shielded from direct water spray to ensure optimal performance and longevity.

Use the following dimensions for the cutout.

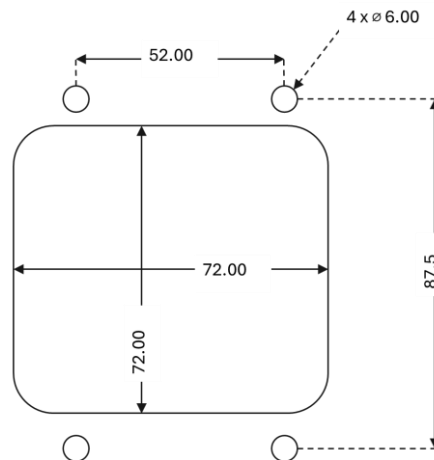

Figure 2: Joystick cutout



### System Status LED Panel Installation:

Install the System Status LED Panel on the dashboard in a location that provides clear visibility. Keep away from direct sunlight and water spray when possible. Use the following dimensions to create an appropriate template for a cutout.

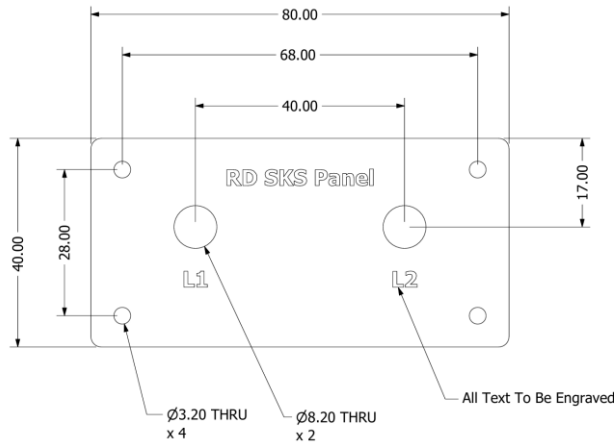

Figure 3: System Status LED Panel

### RD SKS Control Box Installation:

The RD SKS Control Box may be installed in any orientation. It should be positioned to allow for straightforward cable routing and placed as near as possible to the RD SKS Control Helm Joystick. Although the Control Box is rated IP67, installing it in a dry area is recommended to enhance its service life. Exposure to direct sunlight must be avoided. Use the following dimensions to plan installation of the control box.

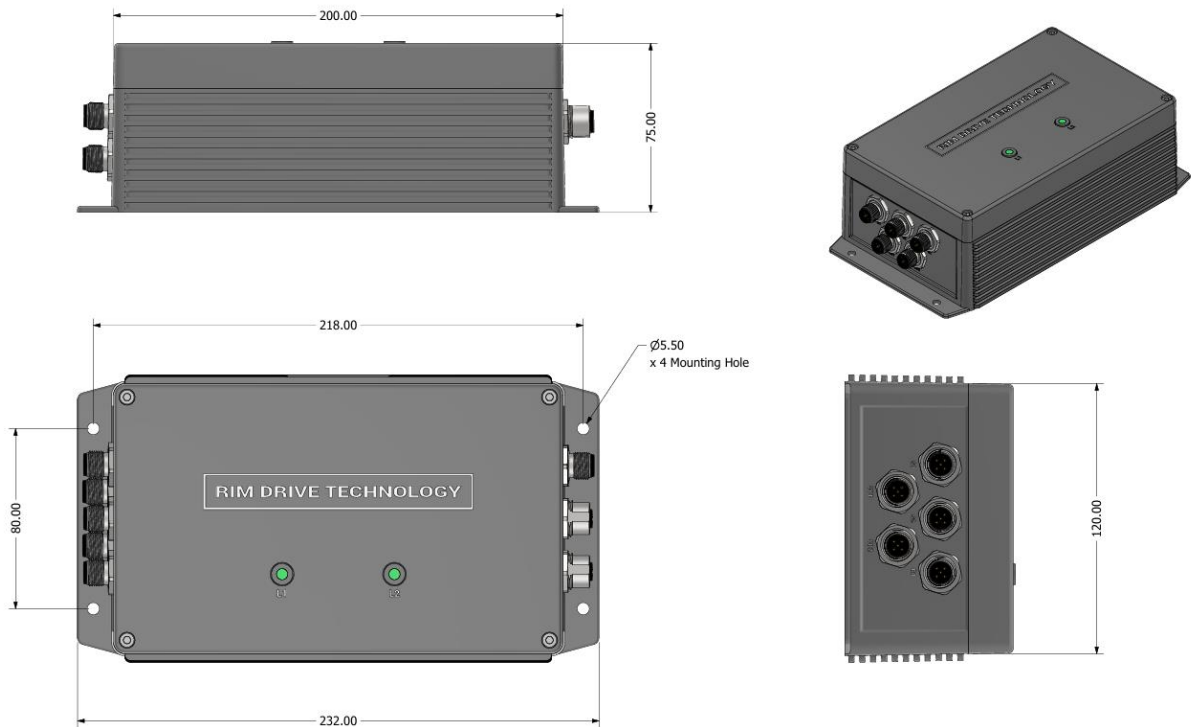

Figure 4: RD SKS Control Box dimensions



# Electrical Installation

Read through this section before wiring the system according to the wiring diagram.

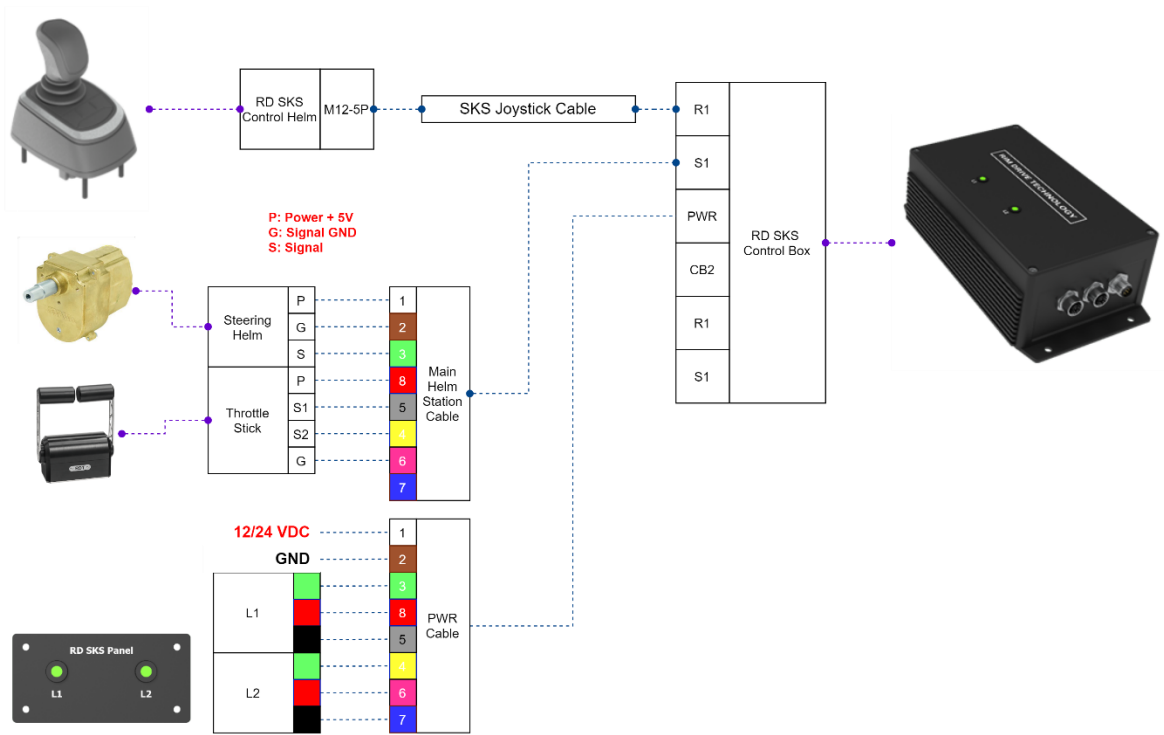
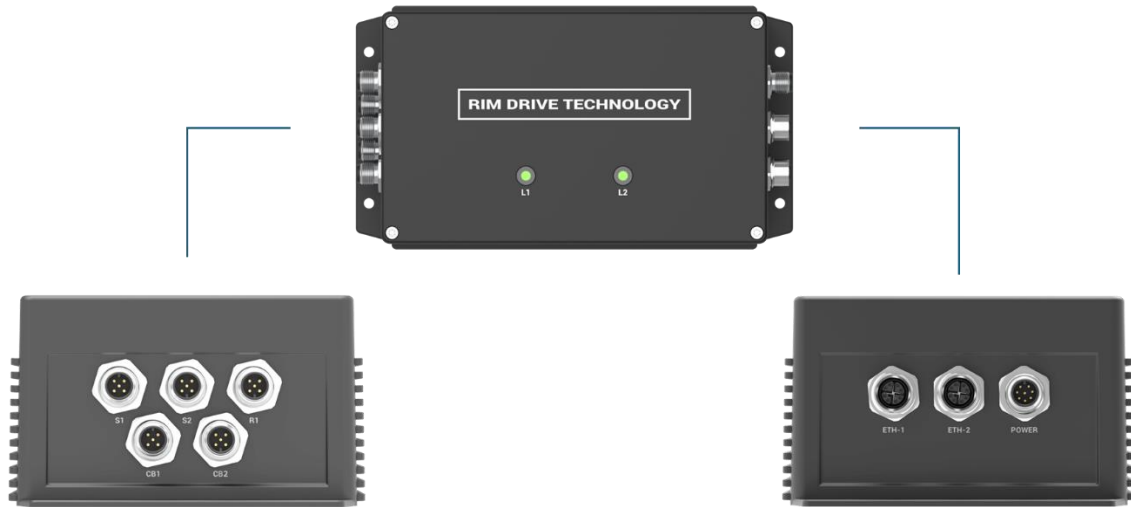

Figure 5: Wiring Diagram



### RD SKS Control Box Port Description



I/O Label	Type <i>Connector gender specified applies to the controller panel connector, not the mating cable</i>	Function
ETH1	M12, A-Code, 8 pin female	Setup port to configuration laptop
ETH2	M12, A-Code, 8 pin female	Connectivity to 4G router
PWR	M12, A-Code, 8 pin male	Power Cable and connection to <i>System Status LED Panel</i>
S1	M12, A-Code, 8 pin female	4 channel analog signals to read commands from the <i>Main Control Helm</i>
S2	M12, A-Code, 5 pin male	RS-232 Port for future integrations if needed
R1	M12, A-Code, 5 pin male	RS-485 Connection to <i>RD SKS Control Helm Joystick</i>
CB1	M12, A-Code, 5 pin male	CAN Bus port for NMEA 2000 connection
CB2	M12, A-Code, 5 pin male	CAN Bus port for CAN Open Port



**Power Port:** Powers the *RD SKS Control Box*. The *RD SKS Control Box* can take a wide input of 10-30 VDC. Recommended fuse size is 2A.

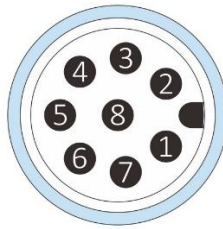

Figure 6: Pin-outs of M12 8 Pin Male

Table 1: Power Cable Pin outs

Pin Number	Function	Cable Color Code
1	Power In – V+ [9-36VDC]	
2	Power In – V+ [9-36VDC]	Brown
3	Panel LED 1 GREEN	Green
4	Panel LED 2 GREEN	Yellow
5	Panel LED 1 GND	Grey
6	Panel LED 2 RED	Pink
7	Panel LED 2 GND	Blue
8	Panel LED 1 RED	Red

**S1 Port:** The S1 port is used to connect the *Main Control Helm* to the *RD SKS Control Box*.

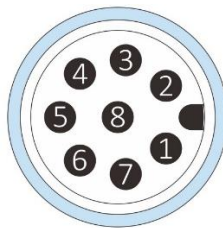

Figure 7: Pin-outs of M12 8 Pin Female

Table 2: S1 Port Main Helm Station Cable Pin-outs

Pin Number	Function	Cable Color Code
1	Power Out – V+ - 5VDC	
2	Power Out – GND	Brown
3	Axis 1	Green
4	Axis 2	Yellow
5	Axis 3	Grey
6	Power Out – GND	Pink
7	Power Out – GND	Blue
8	Power Out – V+ - 5VDC	Red



## Data for positioning System:

The RD SKS can receive position and heading data through two sources. Make sure that you only connect one of them to system.

Source one is via its CB1 port connected to a NMEA 2000 network. The system requires at least 10Hz refresh rate for position and heading to operate correctly.

Source two is via it ethernet connection. Send NMEA 0183 string to the UDP sever with the following address 192.168.10.10 : 5111. When using the second source ensure that all the following strings are sent to the SKS system:

- GGA
- VTG
- HDT

## Connecting to thrusters:

When using the SKS system with Rim Drive thrusters, connect the RIM Drive thrusters CAN Bus to the CB2 port. Ensure that the thruster controllers are setup to accept messages over CAN Bus.

Table 3: CB2 Pinouts

Pin Number	Function	Cable Color Code
1	GND	Brown
2	PWR	White
3	GND	Blue
4	CAN H	Black
5	CAN L	Grey

When using third party thrusters and controllers, refer to the instructions in “RDSKS\_Interface\_Protocol v0.3” to interface with the RD SKS system.



# Operator Manual

The system state defined by a) the helm in control and b) the systems operational mode. The system has four operational modes, namely, *Hold*, *Thrust Vectoring*, *Station Keeping* and *Manual*.

Operational Mode	System Behavior
Hold	The SKS is in safety mode and does not respond to any joystick command

**Thrust Vectoring**

The SKS controller converts helm axis commands to thruster combinations which results in a combination of the following forms of motion.

**Sway**



**Yaw**

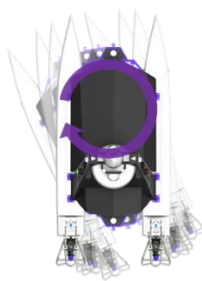

**Surge**

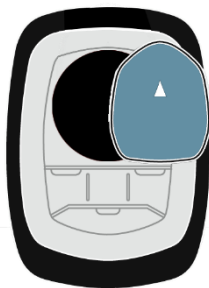



**Station Keeping**

The SKS controller tries to maintain the position and heading of the vessel through feedback from

**Change set point along Port-Stbd Axis**

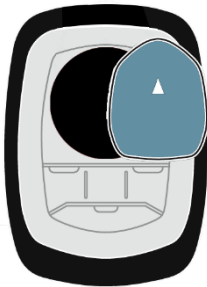
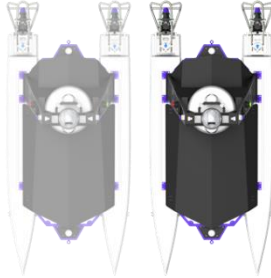

**Change heading set point**

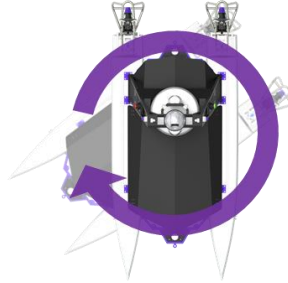

**Change set point along the Fwd-Aft axis**





**Manual**

The SKS controller maps every axis of the active helm to a direct command on one of the thrusters.

*Consider a vessel with two fixed pods and a bow thruster*

Adds a differential thrust to port and stbd pods.  
Increases thrust on port pod and decreases thrust on stbd pod.

Activates bow thruster

Activates both pods in the forward direction

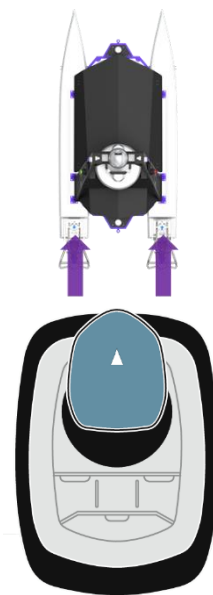
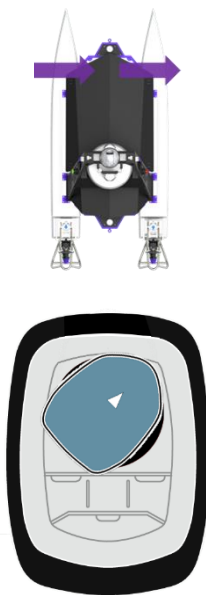
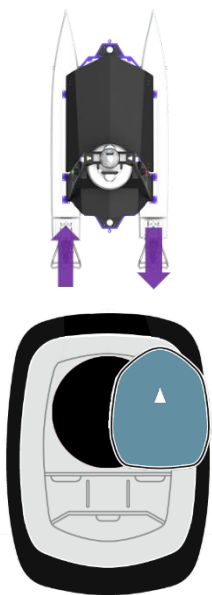



## System Operation Steps:



Figure 8: Joystick Buttons

The system starts in manual mode with the *Main Control Helm* in command. The *Main Control Helm* cannot engage in any mode other than *Manual Mode*.

To take command at the *RD SKS Control Joystick* the user has to press on the *Take Command* button. When pressed the *Take Command* LED on the *RD SKS Control Joystick* starts blinking and then goes solid once a successful transfer of command is completed. The *RD SKS Control Joystick* starts in *Manual Mode* when it takes control.

**Note: Transfer of command cannot be completed if the joystick is not in a neutral position**

To engage station keeping mode at the *RD SKS Control Helm Joystick* press button A. The A LED goes solid when station keeping mode is engaged.

To engage *Thrust Vectoring Mode* at the *RD SKS Control Helm Joystick* press C. The C LED goes solid when *Thrust Vectoring Mode* is engaged.

To go back to manual mode press BOOST. Both LEDs A and C go solid when the *Manual Mode* is engaged.

To release command back to the *Main Control Helm* press the *Take Command* button. Once command is given to the *Main Control Helm* the *Take Command* button turns off.



### Advanced Auto Modes:



Figure 9: Control Keypad

To activate any *Advanced Auto Mode* the *RD SKS* should be equipped with an *Expansion Box* [Check Appendix] and a *Control Keypad*. In order to engage the *Advanced Auto Mode* the *RD SKS Control Helm Joystick* should be in command. Once the *RD SKS Control Helm Joystick* is in command, the user can press the SET THRUST button on the *Control Keypad* to engage the *Advanced Auto Mode*. Once engaged, the SET THRUST button turns green. Furthermore, the user can activate / deactivate the auto course over ground (COG) flag by pressing the AUTO COG button. If activated, the AUTO COG button will turn green.

When the *Advanced Auto Mode* is engaged, the user can increase/decrease the forward thrust of the system by pressing the INCREASE THRUST or DECREASE THRUST buttons.

To deactivate press the SET THRUST button.

Table 4: Joystick Response in Advanced Auto Mode

If the AUTO COG is not activated, the system’s response to the joystick motion is summarized below.

Tries to steer the vessel in the direction of joystick motion



Inactive



Any motion along this axis will deactivate the *Advanced Auto Mode* and put the system into Hold Mode.



If the AUTO COG is activated, the system’s response to the joystick motion is summarized below.

Changes vessel’s COG set point



Inactive









Any motion along this axis will deactivate the *Advanced Auto Mode* and put the system into Hold Mode.





LED Combinations and system states:

Helm in command	Operation Mode	RD SKS Control Helm Joystick LEDs	System Status LED Panel
Main Control Helm	Manual		
		All LEDs off	L1 Off and L2 Solid Green
RD SKS Control Helm Joystick	Manual		
		LEDs A, C and TAKE COMMAND are ON	L1 Off Green L2 Flashing Green
RD SKS Control Helm Joystick	Thrust Vectoring		
		LEDs C and TAKE COMMAND are ON	L1 & L2 Flashing Green



*RD SKS  
Control  
Helm  
Joystick*

Station  
Keeping



LEDs A and TAKE COMMAND are  
ON

L1 Solid Green L2  
Flashing Green

*RD SKS  
Control  
Helm  
Joystick*

Advanced  
Auto Mode  
[Requires  
Keypad]



LEDs A, C and TAKE COMMAND are  
ON



L1 Off Green L2 Flashing  
Green



LED SET THRUST on Keypad Turns  
Green

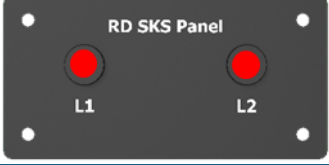

*Error Codes:*

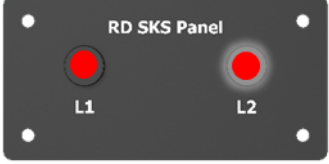
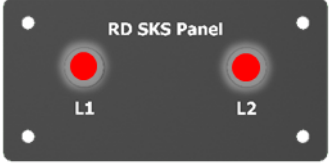
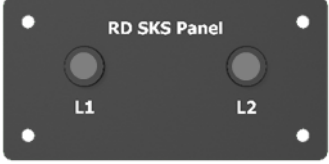
Error	LED 1	LED 2	Illustration
Unreliable or loss of Heading and/or GPS data	Solid Green	Alternating Red / Green	
Loss of communication with thrusters	Solid Red	Solid Red	
Incorrect GPS or Heading data rate	Solid Green	Flashing Red	
Loss of communication to main helm	Solid Red	Flashing Red	
Loss of communication to joystick helm	Flashing Red	Flashing Red	
Loss of power or loss of connection between Status LED panel and Control Box	Off	Off	



## System Configuration:

In order to configure the station keeping system, make sure that you have the following data readily available before starting the configuration of the system.

- Number of thrusters
- Relative location of thrusters
- Types and models of thrusters used

**⚠ Warning: Contact manufacturer for a remote tuning and system configuration session.**

The system currently supports the following thruster configuration. Please thruster configurations that are not listed here kindly contact manufacturer.

- 0: Single steerable thruster with bow thruster
- 1: Single steerable thruster
- 2: Twin fixed thrusters with bow thruster

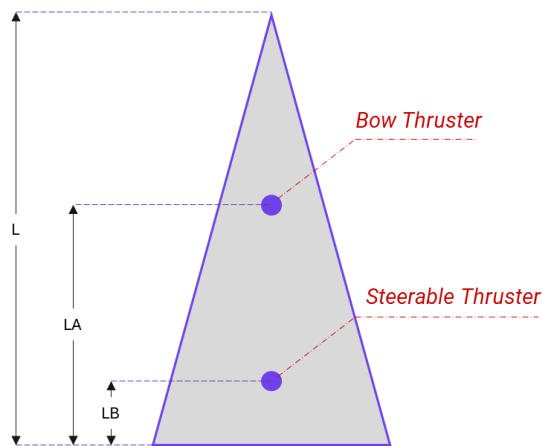

Figure 10: Configuration "0" Geometric Parameters

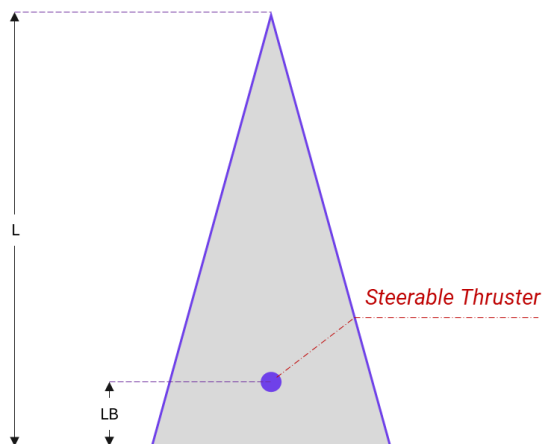

Figure 11: Configuration "1" Geometric Parameters

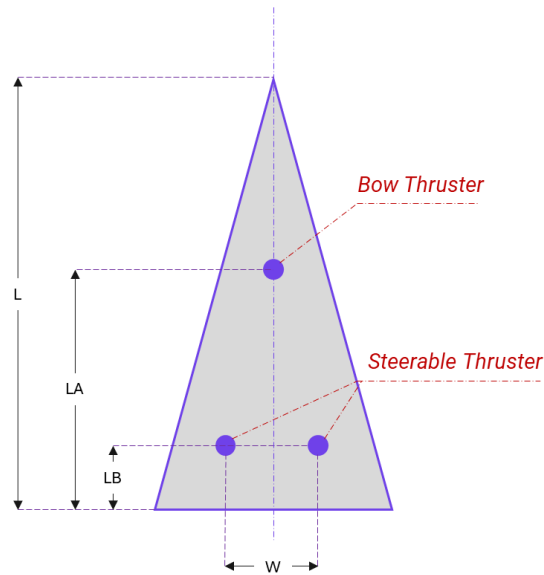

Figure 12: Configuration “2” Geometric Parameters

### Connecting PC to control box:

- 1- Using the provided ETH cable connect the PC to port ETH1 or ETH2.
- 2- Change your PC’s IP Address to “192.168.10.20”.
- 3- Ping the controllers to ensure that the control box is operational. The controller has two IP addresses, namely, “192.168.10.10” & “192.168.10.11”.

### Start the System Tuning and Configuration Tool:

- 1- Install the configuration tool from the provided link
- 2- Start the configuration tool
- 3- The tool shall connect automatically and read current parameters. Given the control box is powered and connected.

### Enter Vessel Configuration Parameters:<sup>1</sup>

**⚠ Warning: Do not arm the thrusters prior to this step**

<sup>1</sup> Changing vessel’s configuration is only accessible to advanced users. Please contact RIM Drive to change the control’s box vessel configuration

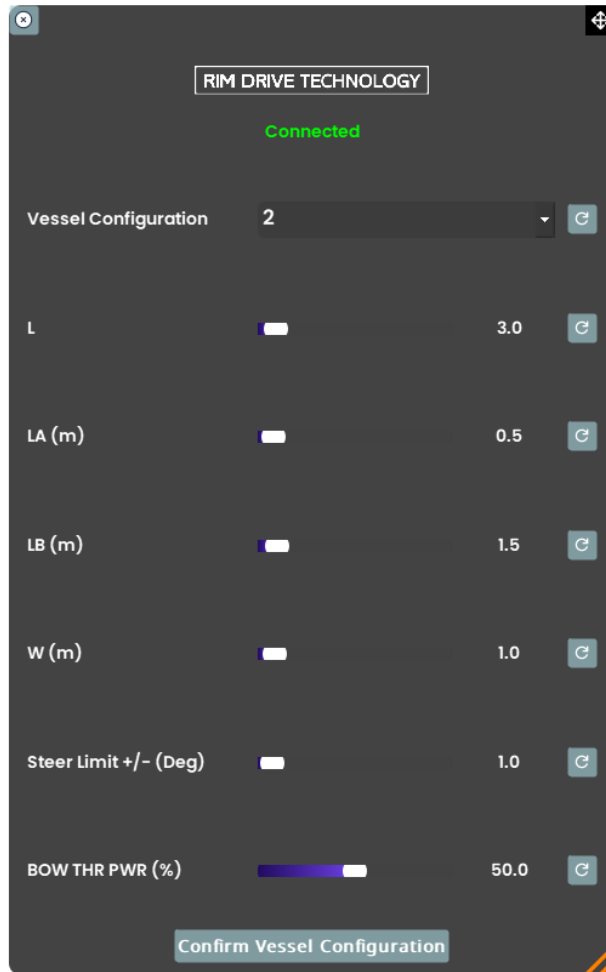

Figure 13: Vessel Configuration View

- 1- Enter the configuration of the vessel parameters and values. All geometric parameters are as explained in Figure 10, Figure 11 and Figure 12.
- 2- Click on “Confirm Vessel Configuration”
- 3- Test the system in Thrust Vectoring Mode to ensure correct configuration

Notes:

- BOW THR PWR is an estimate of the bow thruster power as a percentage of the main thrusters.
- Steer Limit is the steerable thrusters limit in one direction. For example, if your thrusters go steer 45 degrees to port and 45 degrees to starboard (90 degrees of total travel). Enter Steer Limit as 45.



## Controller Tuning:

### Warning:

- **Confirm manual control first:** Do not begin the tuning process until basic manual mode has been tested and verified to function correctly.
- **Choose a safe location:** Perform tuning only in open, unobstructed areas. Avoid busy waterways or locations with heavy traffic.
- **Maintain safety readiness:** Ensure that system disarmament is accessible at all times throughout the tuning process.

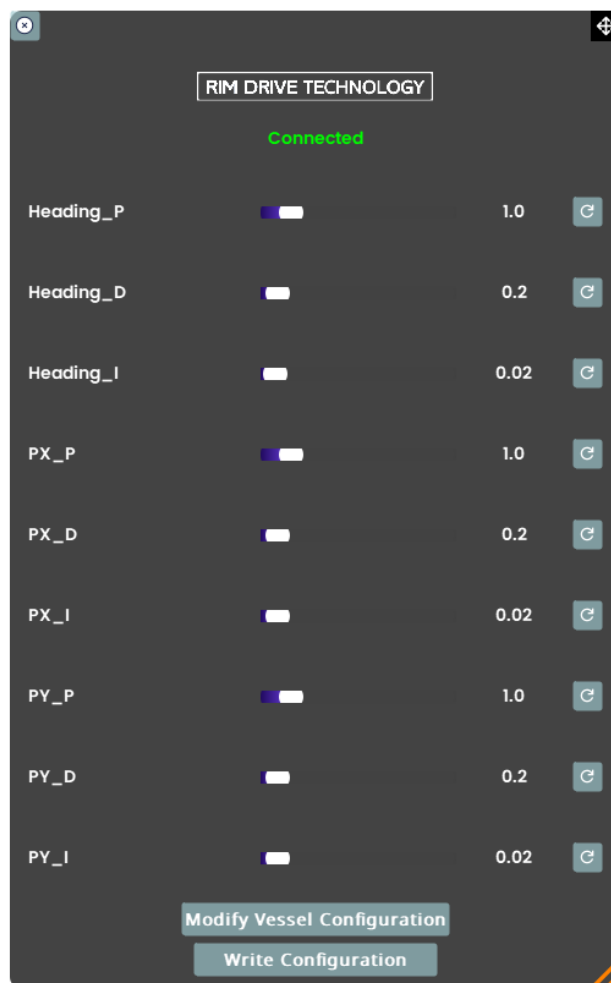

## Heading Controller:

The Heading controller manages how assertively the controller adjusts thrusters commands to adjust the vessel's current heading

- **Heading\_P – Proportional Gain**  
Controls the immediate thrusters response to heading error.  
Higher values result in more aggressive responses.
- **Heading\_I – Integral Gain**



Corrects steady-state error over time.

Typically left unchanged; modify only if persistent heading offset is observed.

- **Heading\_D – Derivative Gain**

Dampens rapid changes in heading to reduce overshooting.

Higher values lead to smoother, more stable responses.

## Position Controller:

The position controller manages the thruster response towards differences between the current position and desired position of the vessel. The system has two position controllers, namely, the x position and y position controllers. The x position controller affects the vessel response along its bow-stern axis and the y position controller affects the vessel response along its port-starboard axis.

- **PXY\_P – Proportional Gain**

Controls the immediate thrusters response to position error.

Higher values result in more aggressive responses.

- **PXY\_I – Integral Gain**

Corrects steady-state error over time.

Typically left unchanged; modify only if persistent positioning offset is observed.

- **PXY\_D – Derivative Gain**

Dampens rapid changes in heading to reduce overshooting.

Higher values lead to smoother, more stable responses.



## Tuning Process:

- 1- Start the PlotJuggler Application to monitor vessel responses and controller commands

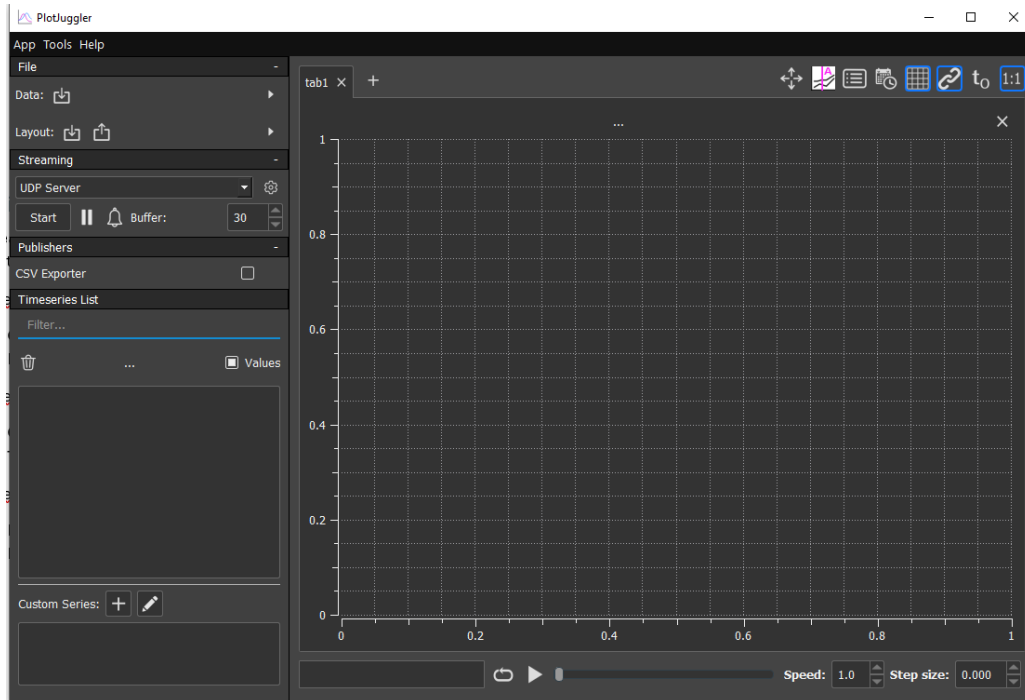

- 2- Enter the following configuration for the UDP Server:
  - a. Port: 4287
  - b. Protocol: JSON
- 3- Load the provided system layout to view heading and position errors
- 4- Engage Station Keeping mode on using the *RD SKS Control Helm Joystick*.
- 5- Modify the control parameters gradually and observe system response.
- 6- Start by tuning the heading controller then transition to position controllers.
- 7- Click on “Write Configuration” once tuning is complete.

## Diagnostics:

The current version shows limited diagnostics and those can be accessed using a web browser. Enter the IP address of the controller “192.168.10.11”.

## Notes:

Access to functions which allow for reversing thrusters and steering directions are currently restricted. Those functions which would be required for a complete system setup are only accessible to certified installers.



## Appendix:

### *Expansion Box:*

An expansion box allows the user to add an additional helm and connect a keypad. The I/Os of the expansion box are as follows:

*Table 5: Expansion Box I/Os*

I/O Label	Type <i>Connector gender specified applies to the controller panel connector, not the mating cable</i>	Function
ETH1	RJ45 water proof connector	Connects to the RD SKS Control Box
ETH2	RJ45 water proof connector	Configuration Port
PWR	M12, A-Code, 8 pin male	Power Cable
R2	M12, A-Code, 5 pin male	Connects to second <i>RD SKS Control Helm Joystick</i>
CB1	M12, A-Code, 5 pin male	CAN Bus port for Keypad 1
CB2	M12, A-Code, 5 pin male	CAN Bus port for Keypad 2



# RIM DRIVE TECHNOLOGY



## **Uncompromised Electric Motors**

[www.rimdrivetechology.nl](http://www.rimdrivetechology.nl)

+31 (0) 85 482 48 55

[info@rimdrivetechology.nl](mailto:info@rimdrivetechology.nl)