

RIM DRIVE TECHNOLOGY



Manual

Stern Thruster

Changes

Version	Date	Changes
1	12-02-2026	Original

Declaration of Conformity

Company name manufacturer	Rim Drive Technology
Company address manufacturer	Wanraaij 4 6673 DN Andelst The Netherlands
Product type	Stern thruster

Foreword

Dear Customer,

We are delighted by the choice for our products. Our stern thrusters systems delivers high-performance by using rim drive technology and is highly efficient. These motors are perfect candidates for those who want to sail electric, as they have a streamlined design, are sustainable and functional. It has been designed and manufactured with an eye on convenience, environment friendly character, user-friendliness and safety. Before shipment, every motor is tested extensively by our test engineers.

Please take the time to read this operating manual carefully as to ensure safe and proper use of the motor. It is always our intention to improve RDT products, for any comments please do not hesitate to contact us.

Please feel free to contact us with any product inquiries. We wish you all the best with our products.

Rim Drive Technology

Content

Changes.....	2
Declaration of Conformity.....	2
Foreword.....	3
1. General.....	6
1.1 Using this user manual.....	6
1.2 Pictograms.....	6
1.3 Copyright.....	6
1.4 Ensure.....	7
1.5 Manufacturer details.....	7
2. Security.....	8
2.1 Appropriate use.....	8
2.2 Requirements for operators.....	8
2.3 Safety.....	9
2.4 Personal Protective Equipment.....	10
2.5 Maintenance/fault removal.....	10
3. Technical data.....	11
3.1 General data.....	11
4. Mounting.....	12
4.1 Mounting standard stern thruster.....	12
4.2 Mounting tunnel and box configuration.....	13
5. Description.....	15
5.1 General.....	15
5.2 Construction.....	15
6. Installation.....	16
6.1 Hardware.....	16
6.1.1 Motor controller.....	16
6.1.2 Fuses.....	16
6.2 Software.....	16
6.3 Batteries.....	16
7. Operation.....	17
7.1 Preparation.....	17
7.2 Operation.....	17
7.3 Stop operation.....	17
7.4 Use frequently.....	17
8. Maintenance & cleaning.....	18
8.1 Maintenance.....	18
8.1.1 Replacement parts.....	19
8.1.2 Corrosion protection.....	19

8.2 Cleaning.....	19
8.3 Dismounting.....	19
9. Service.....	20
9.1. Service activities.....	20
9.2. Registration service claim.....	22
10. Disorders.....	24
10.1 Possible disorders.....	24
10.2 Error codes.....	25
11. Disposal and environment.....	26
11.1 Disposal of waste electrical and electronic equipment.....	26
11.2 Disposal of batteries.....	26
12. General conditions for warranty.....	27
12.1 Warranty and liability.....	27
12.2 Scope of warranty.....	27
12.3 Warranty process.....	28
12.4 Shipment.....	28

1. General

1.1 Using this user manual

Every person who is operating, servicing, maintaining or using the RDT rim drive must have read and understood this manual in detail. The manual provides important instructions for the safe and proper use of the RDT rim drive. After reading this user manual the owner/operator should have an understanding on how to

- Install the product
- Operate the product
- Avoid risks/hazards

Always store this manual close to the RDT rim drive. We advise to store the manual in a waterproof sealing.

The illustrations in this manual are for illustrative purposes only and are not relevant to the design details of the RDT rim drive.

1.2 Pictograms

The following pictograms are used in this manual:



Dangerous situation. If this warning is ignored, personal injury up to death or serious damage to the RDT rim drive may result.



Danger due to electric current. The work may only be carried out by a trained electrician.



Danger of possible damage to the environment.



Note of useful advice on how to use the RDT rim drive.

1.3 Copyright

This is a confidential user manual. All documents are protected within the meaning of the Copy-right Act.

Disclosure and duplication of documents, including extracts, exploitation and communication of their contents are not permitted. Violations are punishable and oblige to pay damages. We reserve all rights of exercise of industrial property rights.

1.4 Ensure

For safe and pleasant operation and use of the rim drive, it is recommended to read this manual in full before installing or commissioning the RDT rim drive. The manufacturer is not liable for damages or improper functioning of the RDT rim drive as a result from failing to adhere to the operating instructions.

Additionally, please read/check the national regulations before the use of the RDT rim drive.

The warranty expires, for example, in the case of:

- Usage for another application than intended by the manufacturer or beyond the applications as described within this manual.
- Installation not in accordance with the manual
- Use of non-original spare parts and complementary products
- Maintenance/servicing by a non-authorized persons/company.
- Operating RDT rim drive outside the water
- Damage caused by journeys through overgrown waters (e.g. reeds) or too shallow waters.

1.5 Manufacturer details

Rim Drive Technology BV

Wanraaij 4
6673 DN
Andelst
The Netherlands

+31 (0) 85 482 48 55
info@rimdrivetechology.nl
www.rimdrivetechology.nl

2. Security

2.1 Appropriate use

In order to provide customers the perfect fit for their application we realized highly configurable products which can be used for the following applications: Leisure marine, commercial marine, unmanned surface vessel (UAV), and subsea. Any other type of application is not allowed without written permission by RDT.

Only power sources which have been approved by RDT should be used in combination with the RDT products.



Danger of destruction! When operating outside the water the RDT rim drive can be destroyed. Operate the RDT rim drive only in water.

The intended use also includes people who are servicing/maintaining or operating the RDT have read and understood this user manual. All procedures described in this user manual must be followed.

The manufacturer is not responsible for damages resulting from operation in a way which is not in accordance with this manual. The risk is exclusively for the user/operator.

2.2 Requirements for operators

Only persons who have the right licenses (according to national law) may use the RDT rim drive as a boat drive.



The required qualification can be found in the applicable national regulations and laws of the country in which the boat is used.

Repair work, follow-up and maintenance/service may only be carried out by persons with the appropriate training and qualifications.

Persons under the influence of drugs, alcohol or reacting drugs are not allowed to carry out work on the RDT rim drive or to operate it.

2.3 Safety

In addition to the information in this manual, observe the general legal and other binding regulations for accident prevention and environmental protection as well as basic health and safety regulations.

- Check if the RDT rim drive is in perfect condition before operating
- Turn on the RDT rim drive only when it is placed completely in water. This is the only way to avoid damage to the RDT rim drive.
- Never remove or change safety devices.
- Before use always inspect the RDT rim drive for (external) recognizable damage and defects. If any damage and/or defects are recognized they must be reported immediately to a RDT qualified service partner.
- Use only professional and qualified maintenance tools.
- After repairs/maintenance, reattach all dismantled protective devices and ensure proper functioning.
- Every operator is responsible to make sure that the RDT rim drive is only operated in perfect/non-damaged condition and that all applicable safety requirements and regulations are complied with.
- Never allow the boat to which the rim drive is mounted to be towed when the system is turned off.
- Make sure all national safety measurements are covered.

2.4 Personal Protective Equipment

Personal Protection Equipment

Personal Protective Equipment (PPE) is important because it protects workers from injuries and accidents. They ensure that employees can work safely. It is therefore important that employees use the correct personal protective equipment and maintain it correctly.

The need for PPEs is well proven and critical to your safety and practically mandatory when servicing a rim drive product. Always check local PPE requirements before boarding a vessel and/or commencing service.

As a Rim Drive Technology service engineer your PPE's should be:

- Be compliance with our work instructions
- Be compatible with any other equipment you use at the same time
- Be appropriate for the risks involved, and the task being performed, without itself leading to any significant increased risk (e.g. using gloves, hearing protectors, safety glasses..).
- Ensure that you always work with safe and approved resources such as machines, tools and devices.
- Take responsibility to stop unsafe activities and to intervene in unsafe situations.

What PPE's are recommended to bring when working with rim drive product?

- Eye protection (e.g. safety glasses)
- Ear plugs or hearing protection
- Proper fitting working cloths
- Life jacket / drowning protection (e.g. working outboard).
- Safety gloves (suitable for working with oil/glue)
- Safety shoes (toe cap and anti-slip)
- Other PPE's locally required

2.5 Maintenance/fault removal

Check the deadlines for regular inspections specified in the user manual.

Use only the professional/qualified tools for maintenance/fault removal.



Danger from electric current! Incorrect work on the power supply may result in damage to the RDT rim drive. Work on the electrical equipment of the RDT rim drive may only be carried out by a certified electrician.

3. Technical data

3.1 General data

Model	Stern thruster	Stern thruster	Stern thruster	Stern thruster	Stern thruster	Stern thruster	Stern thruster
Type	0.5	2,5	3.0	4.2	5.0	8.0	11.0
Input voltage	48	24	48	24	48	48	48
Nominal power	0.5	2.5	3.0	4.2	5.0	8.0	11.0
Maximum RPM	4.000	3.200	4.000	1.750	2.500	2.000	1.500
Maximum temp.	85°C	85°C	85°C	85°C	85°C	85°C	85°C
Temp. sensor	PT1000	PT1000	PT1000	PT1000	PT1000	PT1000	PT1000
Maximum depth*	5 meters	5 meters	5 meters	5 meters	5 meters	5 meters	5 meters

Stern thruster	Stern thruster	Stern thruster	Stern thruster	Stern thruster	Stern thruster
15.0	22.0	25.0	30.0	50.0	75.0
48	48V/96V	96	110	400	400
15.0	22.0	25.0	30.0	50.0	75.0
1.700	1.200	1.000	1.000	1.200	1.400
85°C	85°C	85°C	85°C	85°C	85°C
PT1000	PT1000	PT1000	PT1000	PT1000	PT1000
5 meters	5 meters	5 meters	5 meters	5 meters	5 meters

* For subsea motors depending on cable configurations and production methods.

4. Mounting

4.1 Mounting standard stern thruster

For mounting the stern thruster, several mounting options are available.

The first option uses the mounting socket on top of the motor, which is described below.

Use the two holes pattern on the mounting socket when mounting the motor.

- Only mount the motor to a strong and stable mounting bracket.
- See drawings below for mounting holes pattern (6x M10). At least 4 holes should be used.
- Use Loctite 577 on the thread of the M10 stud bolts when mounting the motor.
- The material of the bolts has to be AISI Type 316L stainless steel and with the help of a torque wrench (18 Nm) screw in the bolts.
- The bolts must be mounted so that the thread is completely filled.

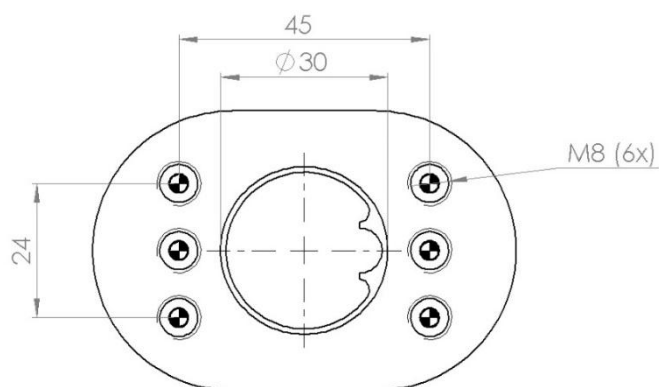

Figure 1: Mounting for the 0.5kW propulsion motors.

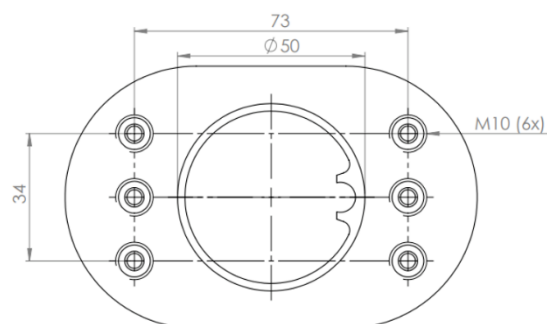

Figure 2: Mounting for the 3.0, 5.0, 8.0kW and 11.0kW propulsion motors.

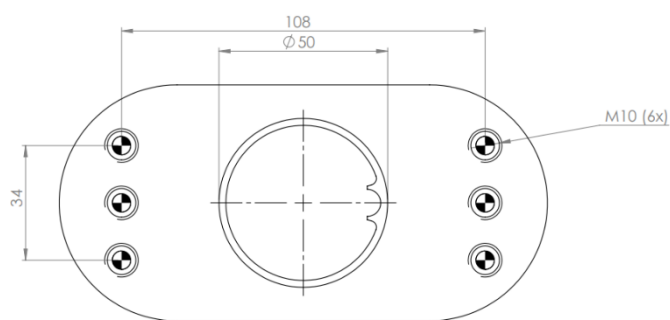

Figure 3: Mounting for 15kW propulsion motors.

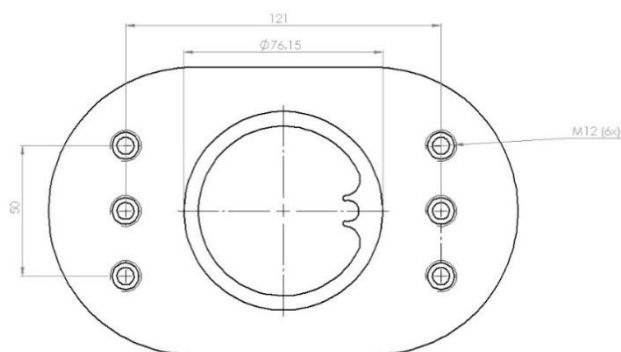

Figure 4: Mounting for the 25/30/50kW propulsion motors.

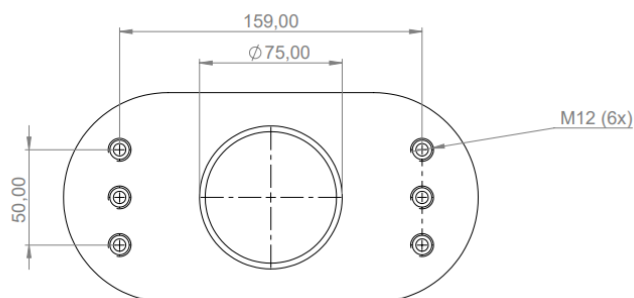
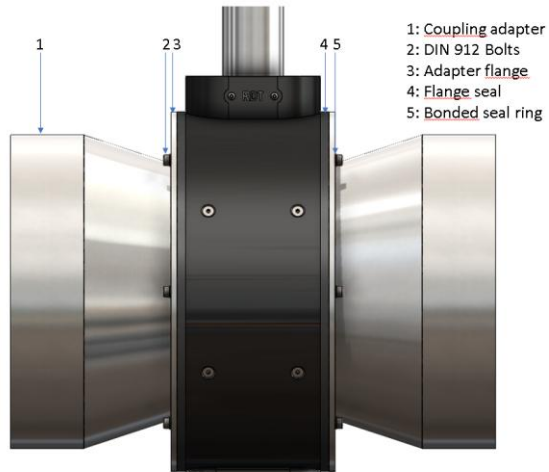

Figure 5: Mounting for 75kW propulsion motors.

4.2 Mounting tunnel and box configuration

On request, a stern thruster can also be supplied in a tunnel or box configuration.

The second option for mounting a stern thruster is to make use of the available stern thruster tubes and couplings. This configuration is as seen below:



Before installing the stern thruster, verify no damage is visible on the flange seal and extends beyond the motor outside diameter. Furthermore, ensure all bolts are correctly installed with a bonded seal ring and are correctly tightened using a correctly set torque wrench. When installing the stern thruster, take care to ensure proper seal.

For a third option you can use directly mounted stern thruster tunnels with the correctly sized flanges. The system would look approximately as shown below.



When mounting the motor to the flanges, ensure the following points are considered and addressed. The flanges need to extend beyond the motor outside diameter for a complete seal the motor. For mounting the bolts we advise to use a self-centering bonded seal to prevent water ingress past the bolts. In order to prevent damaging the system make sure to use a correctly set torque wrench.

A fourth option is to make use of a stern thruster box. The box can be manufactured by the client or obtained from RDT. Here the stern thruster tunnels meet at a box with inside dimension of the motor size used, which places the motor concentric with the stern thruster tunnels.

To install the stern thruster box the first step is to connect the tube ends. For the Aluminium, HDPE or Stainless steel version this could be done by welding or clamps. For the GFK version the tubes need to be laminated in, with the lamination extending all the way to the box itself for longevity.

After fixing the box within the vessel, ensure this step is waterproof. Next the motor needs to be mounted to the lid using the provided small gasket and bolts. Over the bolts bonded seals are required for additional protection against water egress. Secure the bolts to the correct torque value as provided within the table.

Motor size	Bolt size	Torque
0.5 (M065)	M8	12 Nm
2.5-15.0 (M086-M212-Pro)	M10	20Nm
22.0-75.0 (M290-M341-Pro)	M12	40Nm

With the motor fixed to the lid, place the seal on top of the box. Slide the motor assembly in while ensuring the seal is not damaged. Install the provided bolts to hand tight. Then in a cross-wise pattern fasten the bolts to the torque value specified below

Box Size	Stainless/Aluminium	HDPE/GFK
0.5 (M065)	10Nm#	4Nm#
2.5-15.0 (M086-M212-Pro)	15Nm#	6Nm#
22.0-75.0 (M290-M341-Pro)	25Nm#	20Nm#

Ensure the installation is waterproof before launching the vessel.



Danger of broken motor! When the motor is not installed in the right way there is risk for a broken motor.

5. Description

5.1 General

The installation location can be chosen by the client as long as it can be mounted securely and in accordance with this manual. In case of any questions, please contact a RDT or a RDT qualified service center.

The rim drives have been designed in such a way that the power supply can be provided by generators or battery packs.

5.2 Construction

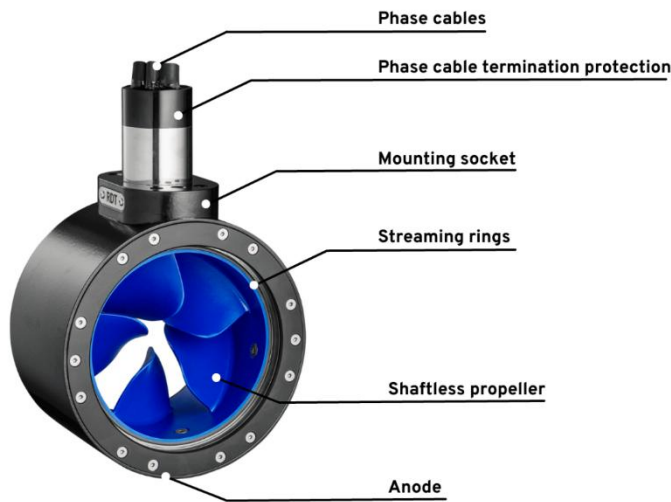

The connection of the RDT rim drive to the hull is depending on the location of connection.

A sticker is connected to each motor, it records the key data as per the EC machinery directive 2006/42/EC.

6. Installation

6.1 Hardware

For the installation always refer to a professional and trained company. The motor controller, batteries, throttle controls and other products shall only be installed as described by Rim Drive Technology.

No client, installation company, dealer or any other person/company is allowed to make any changes to the hardware/software.

All safety equipment like kill switches, fuses, relays, other type of safety products should be installed by a professional and trained company according regulation/law for the country within which the products are used.

When verifying the correct operation of the motor, ensure all DC connections are checked immediately after reaching full power. When performing this check directly after full power is applied, all connections should not be warm to the touch. If connections are hot to the touch, please reinstall the DC connections.

After 10 and after 50 hours of running the motor the mounting socket bolts have to be checked.

6.1.1 Motor controller

Depending on the choice of motor controller, a wiring schematic should be followed. Always contact RDT for the manual of the motor controller. The motor controller should be connected using shielded cables which are preferably located in stainless steel or aluminum tubing.

6.1.2 Fuses

To ensure a safe system several fuse(s) have to be installed. RDT is not responsible for damage occurred by fuses which were not delivered by RDT.

6.2 Software

Rim Drive Technology will provide software which is developed for the specified configuration. Nobody is allowed to make any changes to the software, except Rim Drive Technology.

6.3 Batteries

The motors could additionally be used as a generator. Make sure that the used configuration is suitable for this purpose. A reverse voltage can be applied to the system which might require consideration in certain applications.

7. Operation

7.1 Preparation

Ensure the following preparations have been carried out before operating the RDT products.
Unplug the cable/plug from the power supply.
Store the charging cable in a way which as to prevent damage or tripping.
Check the remaining capacity of the batteries.



Do not put the RDT rim drive into operation if the remaining battery capacity is $< 20\%$

7.2 Operation

Ensure the following preparations have been carried out before operating:

- Turn on the power supply for the RDT rim drive.
- Ensure the motor can be put forwards and backwards without noise etc.
- Regularly check the remaining battery capacity during operation. Otherwise there is a risk of having no propulsion.



If an extension tube is mounted to the motor, a sealing/barrier must be installed between the tube and the motor, to prevent galvanic corrosion damage.

7.3 Stop operation

Ensure the following actions have been carried out when stopping the use of the RDT rim drive:

- Turn off the power supply for the RDT rim drive.
- Connect the charging cable to the charger.
- Make sure that the charging cables are placed in a safe way as to prevent tripping or accidental damage.



Lay down the charging cable as to prevent damage.

7.4 Use frequently

The motor has to be used for a minimum of five hours every month to make sure the bearings will not seize up.



For the 22kW motor, Do not run the motor at full power immediately. The motor must first be run in temporarily at a lower power to ensure proper operation and a long service life.



For the 25 kW, 30 kW, 50 kW, and 75 kW motors a specific running-in procedure is required. Do not operate these motors without prior guidance from RDT. Contact RDT before initial use.

8. Maintenance & cleaning

8.1 Maintenance

Have the RDT rim drive checked at least once a year by Rim Drive Technology or by an authorized specialist to check for perfect condition. If damage is discovered, it must be rectified immediately by a RDT service partner before operating. Do not use the RDT product when it is damaged.



Danger of destruction! Maintenance should only be performed by authorized personal/ service centers. Otherwise, errors may occur which can lead to the destruction of the rim drive. Rim Drive Technology accepts no liability for damages caused by improper maintenance.

Maintenance level	Executor	Working hours	Time
Maintenance level 1	Client	5 hours	Every run
Maintenance level 2	Client	100 hours	One year
Maintenance level 3	RDT Service partner	1.000 hours	Five years

Service task	Level 1	Level 2	Level 3
Test functionality	Propeller turns forward Propeller turns reverse Motor is reacting fast		
Cable connections		Check for damage Visual check Check connectors	
Batteries and cables		Visual check of cables Visual check of connectors Visual check of connections	
Anode		Replacement	
Mechanical connection to hull		Test and repair if necessary	
Waterproofness			Visual check of complete motor
Full product test			Control propeller quality

*The client is responsible to contact a RDT authorized service center for maintenance level 3.

8.1.1 Replacement parts

For information on spare parts and the installation of these parts, contact Rim Drive Technology or an authorized Service Partner. Only RDT spare parts may be used.

8.1.2 Corrosion protection

A high level of corrosion resistance is ensured by the design of the products and with the selection of the materials. All materials are classified as sea water resistant materials.

To reduce the chance of corrosion:

- Check the anode latest every 6 months. Change the anode every 12 months or after >50% of anode has been destroyed by environment.
- Regularly apply a suitable contact spray (e.g. Wet protect) to cable contacts, data sockets, and data plugs.
- The use of anti-fouling agent is forbidden.
- Only mount original RDT anodes to the rim drive motor. Otherwise no guarantees can be given.

8.2 Cleaning

Before starting turn off the power supply, as to prevent accidental activation during the cleaning process.



Injury! When the power supply is switched on, the rim drive may cause injuries to the limbs when cleaning the RDT rim drive.

The cleaning intervals depend on the area of application and the number of operating hours. At least, the rim drive must be cleaned once a year in fresh water.

In case of contaminated, salt water or with frequent use of the rim drive; the interval between cleaning should be shortened.



Only use fresh water for cleaning.

8.3 Dismounting

The client is not allowed to dismount, remove or disassemble any parts from the products. Examples of activities which are not allowed without written approval:

- Removal of mounting rings with bearings
- Removal of rotor housing
- Removal of cables
- Removal of mounting socket

9. Service

9.1. Service activities

Video instructions on the various service activities can be found in the digital training platform for our distributors.

Replacing a propeller

Motor	Bolt type *	Allen wrench	Points of attention
2.5 / 3.0kW	DIN 7991 M4x8	2.5	- Torque wrench: 1.5Nm - Use TIKAL TEFGEL
4.2 / 5.0kW	DIN 7991 M5x8	3	- Torque wrench: 2.5Nm - Use TIKAL TEFGEL
8.0kW	DIN 7991 M5x12	3	- Torque wrench: 2.5Nm - Use TIKAL TEFGEL
11.0kW	DIN 7991 M5x12	3	- Torque wrench: 2.5Nm - Use TIKAL TEFGEL
15.0kW	DIN 7991 M5x12	3	- Torque wrench: 2.5Nm - Use TIKAL TEFGEL
25.0 up to 75.0kW	DIN 7991 M6x22	4	- Torque wrench: 6Nm - Use TIKAL TEFGEL

* Stainless steel 316

Installing mounting rings**

Motor	Bolt type*	Allen wrench	Points of attention
0.5kW	DIN 7991 M3x16	2	- Torque wrench: 0.75 Nm - Check that the rotor bearings are straight in the mounting ring bearings before tightening the bolts. - Use TIKAL TEFGEL
2.5 / 3.0kW	DIN 7991 M3x20	2	- Torque wrench: 0.75 Nm - Check that the rotor bearings are straight in the mounting ring bearings before tightening the bolts. - Use TIKAL TEFGEL
4.2 / 5.0kW	DIN 7991 M4x20	2.5	- Torque wrench: 1.5Nm - Check that the rotor bearings are straight in the mounting ring bearings before tightening the bolts. - Use TIKAL TEFGEL
8.0kW	DIN 7991 M5x20	3	- Torque wrench: 2.5Nm - Check that the rotor bearings are straight in the mounting ring bearings before tightening the bolts. - Use TIKAL TEFGEL

11.0kW	DIN 7991 M5x20	3	<ul style="list-style-type: none"> - Torque wrench: 2.5Nm - Check that the rotor bearings are straight in the mounting ring bearings before tightening the bolts. - Use TIKAL TEFGEL
15.0kW	DIN 7991 M5x20	3	<ul style="list-style-type: none"> - Torque wrench: 2.5Nm - Check that the rotor bearings are straight in the mounting ring bearings before tightening the bolts. - Use TIKAL TEFGEL
25.0 up to 75.0kW	DIN 7991 M6x30	4	<ul style="list-style-type: none"> - Torque wrench: 6Nm - Check that the rotor bearings are straight in the mounting ring bearings before tightening the bolts. - Use TIKAL TEFGEL

* Stainless steel 316

**This part should only be done by a provided service center.

Replacing inlet / **outlet ring** weg

Motor	Bolt type*	Allen wrench	Points of attention
0.5kW	DIN 912 M3x20	2.5	<ul style="list-style-type: none"> - Torque wrench: 1.5 Nm - Use TIKAL TEFGEL
3.0kW	DIN 912 M3x25	2.5	<ul style="list-style-type: none"> - Torque wrench: 1.5 Nm - Use TIKAL TEFGEL
5.0kW	DIN 912 M4x25	3	<ul style="list-style-type: none"> - Torque wrench: 1.5Nm - Use TIKAL TEFGEL
8.0kW	DIN 912 M5x25	3	<ul style="list-style-type: none"> - Torque wrench: 5Nm - Use TIKAL TEFGEL
11.0kW	DIN 912 M5x25	4	<ul style="list-style-type: none"> - Torque wrench: 5Nm - Use TIKAL TEFGEL
15.0kW	DIN 912 M5x25	4	<ul style="list-style-type: none"> - Torque wrench: 5Nm - Use TIKAL TEFGEL
25.0 up to 75.0kW	DIN 912 M6x40	5	<ul style="list-style-type: none"> - Torque wrench: 12Nm - Use TIKAL TEFGEL

* Stainless steel 316

9.2. Registration service claim

It is important for us that we meet your expectations. Each product has been produced and tested intensively before shipment to worldwide clients. If nevertheless a warranty claim should occur, it will be assessed with the aim of resolving the claim in a timely and effective manner.

For a flawless process we need your cooperation:

- Please complete this registration service claim form.
- Please provide a copy of your proof of purchase (invoice).
- Please send this form to: sales@rimdrivetechonology.nl
- Please understand that we have to reject received products which the company was not notified of.
- Please ensure suitable, protected packaging.
- Please be advised that lithium batteries are designated as Dangerous Material. The dispatch of the battery with a transport company has to be organized according to the formalities for dangerous goods and packed in the original packaging.
- Please observe the warranty conditions as listed in the User Manual chapter 12.

Registration service claim

Contact details

First Name:	Last name:
Address:	City, State, Zip Code / Postcode:
Country:	E-mail:
Telephone No.	Mobile No.
When existing: Customer ID	

Details of claim

Exact product name:	Article no.	Serial no.
Date of purchase:	Hours of use:	
Dealer where product was purchased:	Address of dealer: (City, State, Zip Code / Postcode, Country)	
Detailed description of problem (including error message)		
Description of the products of the system that are included:		

10. Disorders

10.1 Possible disorders

Make sure that the power supply is switched off and is secured against activation.



Injury! When the power supply is switched on the rim drive may cause injuries to the user.

Disorder	Possible cause	Fix
The rim drive is not running.	<p>The main switch is not turned on.</p> <p>The batteries are empty.</p> <p>The propeller is blocked.</p> <p>Connection/Wiring is not correct/bad.</p> <p>The motor controller gives an error.</p>	<p>Turn on the main switch.</p> <p>Charge the batteries.</p> <p>Check if the propeller is damaged.</p> <p>Check wiring and connections.</p> <p>Restart the system</p>
The batteries are not charging.	<p>The plug from the charging cable is not properly plugged into the land-side power supply.</p> <p>The land-side power supply is switched off.</p> <p>The batteries are defect.</p>	<p>Insert the plug correctly into the land-side power supply.</p> <p>Turn on the land-side power supply.</p> <p>Replace the defect batteries.</p>

10.2 Error codes

The following table describe all the error codes that the controller will display. The presence of an error can be detected by means of a red led flashing on controller (number of flashes correspond to base error code). The error codes are divided in four different categories, based upon the severity of the faults.

Base fault Code	Description
Controller warning faults – Reduces only performance – Fault will reset itself (if possible)	
0	No error
1	N/A
2	Voltage getting low
3	Inhibit drive/ BDI Cut / BLC via scan
4	Voltage getting high
5	Motor temperature high
6	Controller temperature high
7	Adjustment out of range
8	Default adjustment used
Drive error faults – Commences graceful neutral brake – Requires a neutral recycle action to reset fault	
9	Memory chip fault
10	Both forward and reverse inputs active
11	Ride-on: Seat switch not closed or timed out. Walkie: Tiller switch not closed
12	Power up sequence fault
13	Accelerator more than 50% at power up
14	Inching sequence faults
Soft error faults – Immediately stops pulsing – Requires a neutral recycle action to reset fault	
15	Supply voltage fault
16	N/A
17	Battery voltage too low
18	High sided mosfets short circuit
19	Motor stall protection

Hard error faults – immediately stops pulsing and open line contactor – Reset only by a key switch recycle	
20	Hardware over current detected
21	Contactor coil driver fault (e.g. short circuit)
22	Voltage is too high
23	Low sided mosfets short circuit in neutral
24	Hardware fail safe fault
25	Line contactor (e.g. short circuit)
26	Thermal shutdown fault (only for minimum pump speed fault)
27	Low sided mosfets short circuit during power up and before line contactor is closed.
28	Wire off detected
29	CAN node fault
30	Motor over speeding
31	Motor fault
32	Motor Module initialization error
33	Motor Module configuration inconsistency
34	Motor Module parameter inconsistency
35	Current sensor calibration fault
36	Controller temperature over 100 degree
39	Generic time out
40	System fault

1 1. Disposal and environment

1 1.1 Disposal of waste electrical and electronic equipment

For customers in EU countries

RDT permits all clients to follow the European Directive 2012/19/EU relating to Waste Electrical and Electronic Equipment – WEEE, and to the corresponding national laws. The WEEE Directive forms the basis for handling waste electrical equipment across the whole of the EU. The RDT system is marked with the symbol of a crossed-out rubbish bin. Waste electrical and electronic equipment must not be disposed of as normal household waste, because this could allow entry of pollutants to the environment which have effects injurious to health on humans, animals, and plants, and which build up in the food chain and in the environment. In addition, valuable raw materials are lost in this way. Please therefore direct all waste equipment for separate collection in an environmentally friendly way.



For customers in other countries

RDT permits all clients to follow the European directive 2012/19/EU regarding waste electrical and electronic equipment. We recommend that the system is not discarded as normal household waste, rather this should be disposed of via separate collection in an environmentally friendly way. The applicable national laws may also prescribe this. Therefore, please ensure appropriate disposal of the system as per the regulations which apply in the country within which the rim drive is used.

1 1.2 Disposal of batteries

Remove spent batteries immediately, and comply with the following specific disposal information relating to batteries or battery systems:

For customers in EU countries

RDT permits all clients to follow the European directive 2006/66/EC regarding (spent) batteries, as well as to the corresponding national laws. Here the Battery Directive forms the basis for handling batteries throughout the EU. Our batteries are marked with the symbol of a crossed-out rubbish bin. Spent batteries must not be disposed of as normal household waste, because this could allow pollutants to enter the environment which could have effects injurious to health on humans, animals, and plants, and which build up in the food chain and in the environment. In addition, valuable raw materials are lost in this way. Please therefore dispose of the spent batteries exclusively via specially set-up collection points, the dealer, or the manufacturer. There is no charge for handing them in.

For customers in other countries

RDT permits all clients to follow the European directive 2006/66/EC regarding (spent) batteries. The batteries are marked with the symbol of a crossed-out rubbish bin. We recommend that the batteries are not discarded as normal household waste, rather this should be disposed of via separate collection. Your national laws may also prescribe this. Therefore, please ensure appropriate disposal of the batteries as per the regulations which apply in the country within which the rim drive is used.

12. General conditions for warranty

12.1 Warranty and liability

The statutory warranty runs for and includes all components of the RDT system. The client needs to activate the warranty within 30 days after delivery via our website: www.rimdrivetechology.nl

The warranty period starts from the day of delivery of the RDT system to the end customer.

12.2 Scope of warranty

Rim Drive Technology, Wanraaij 33, 6673 DM, Andelst guarantees the end customer of a RDT system, the product is free from material and manufacturing defects during the period of coverage defined below. Rim Drive Technology will indemnify the end customer for the costs of correction of a material or manufacturing defect. This indemnification obligation does not apply to any incidental costs caused by a warranty case or to any other financial detriment (e.g. costs for towing, telecommunication, accommodation, subsistence, loss of use, lost time, etc.).

The warranty terminates two years from the day of handover of the product to the end customer. Products used - even temporarily - for professional or official purposes are excluded from the two-year warranty. For these uses, the statutory warranty applies. The guarantee claim expires six months after the discovery of the defect.

Rim Drive Technology decides whether defective parts are repaired or replaced. Distributors and dealers who carry out repair work on Rim Drive Technology motors have no power to make legally binding statements on behalf of Rim Drive Technology.

Wearing parts and routine maintenance are excluded from the warranty.

Rim Drive Technology has the right to refuse warranty claims if:

- The warranty was not submitted correctly (especially failure to make contact before dispatching goods under complaint, absence of a fully completed warranty form and of proof of purchase; see warranty process).
- The product has been used in a manner contrary to instructions.
- The safety, operating, and care information in the instructions were not followed.
- Prescribed maintenance intervals were not complied with and documented.
- The purchased item was in any way converted, modified, or equipped with parts or accessory items which are not expressly authorized by Rim Drive Technology or which do not form part of recommended equipment.
- Previous maintenance or repairs were undertaken by companies not authorized by Rim Drive Technology, or parts other than original replacement parts were used. This applies unless the end customer can prove that the circumstances resulting in the refusal of the warranty claim have not encouraged the progress of the defect.
- The product has been used for other applications as described.

In addition to the claims arising from this warranty, the end customer has statutory warranty rights arising from his purchase contract with the relevant dealer; these are not restricted by this warranty.

12.3 Warranty process

It is a prerequisite that the warranty process described below is followed for the fulfilment of warranty claims.

For the problem-free handling of warranty cases, we request that the following instructions are complied with:

- In the event of a claim, please contact Rim Drive Technology. RDT will provide a return number.
- Should it be necessary to transport products to Rim Drive Technology premises, please note that inappropriate transport is not covered by guarantee or warranty.

For queries regarding the warranty process, we can be contacted by means of the details given in this manual.

12.4 Shipment

The client is responsible for shipment, costs and any damage or loss which are related to this shipment.

RIM DRIVE TECHNOLOGY

**Uncompromised
Electric Motors**

www.rimdrivetechology.nl

+31 (0) 85 482 48 55

info@rimdrivetechology.nl