

RIM DRIVE TECHNOLOGY



English

Catalogue

Electric propulsion systems for leisure, commercial and subsea applications.



FORGET
EXHAUST GASSES,
VIBRATIONS AND NOISE



Andelst, The Netherlands

Table of contents

Our mission	4
Propulsion configurations	6
Bow thruster configurations	7
POD	8
Steerable PODs	10
Outboards	14
Standard bow thruster	18
Bow thruster tunnel set	20
Bow thruster box	22
System functionalities	24
Batteries	28
Chargers	31
Accessories	32

Our mission

Our mission is to convince customers. Convince them that our motors work for many hours with a service intervals and the highest user experience. If we succeed with this mission, we will advance on our vision of a better eco-friendly future.

Purpose

Our purpose is to help as many people and companies as possible with the transition to electric boating.

Quality control

In order to guarantee the quality of our products, our production is located in the Netherlands. Not only is the production quality higher here, the monitoring of the quality is also a lot easier.

Accessories

We want to support our customers from start to finish. To realize this, we offer a wide range of accessories which increases the user friendliness of our motors. To provide the best customer experience, our accessories work efficiently with all our rim drive products.

Worldwide

We are operating in more and more markets in different countries. We are proud that our motors continue to be part of countless projects and applications around the world.

Sustainable

Our organization actively contributes to a sustainable world by developing innovative solutions for environmental challenges.

Did you know?

- A Rim Drive contains no oils and sealings.
- Rim Drive motors were founded in 1929.
- Our systems are also compatible with most other marine brands.
- We are a CO2 neutral company due to compensation via treesforefree.nl
- We design and develop all parts in the Netherlands.
- A Rim Drive accelerates within 1.5 seconds from zero to full RPM.



A Revolution in Propulsion

A Rim Drive contains its electric winding in the outer (stator) housing. This housing is casted to avoid any use of sealings. The inner housing which contains the magnetics is also potted to avoid any internal corrosion. The bearing system is water lubricated and will last for thousands of hours by normal use.

The combination of the inlet ring, outlet ring and propeller makes it the most efficient way of propulsion. Each part has been simulated via CFD analysis and intensively tested in real circumstances.

Why a Rim Drive?

- The POD 3.0, 5.0 and 11.0 can be switched easily due to the same mounting pattern.
- Rim Drive 30.0 and 50.0 have the same dimensions.
- Clockwise, counter clockwise and symmetric directions are available for every motor.
- All our products are saltwater resistant to ensure ease of installation for every boat.
- Rim Drives are available in POD, steerable POD, outboard and bow thruster.
- Rim Drive motors are sold in many other countries through our distributors.



An **immediate** acceleration response in comparison with conventional solutions.

A **compact** and **lightweight** design makes our products compatible for the smallest installation.

Because of the **stepless** controlling our rim drive motors can be operated proportionally.

No center shaft **limits** the chance that ropes, or fishing nets will get stuck in the propeller.

Only one rotating part which **reduce** the amount of maintenance.



Propulsion

POD

The better alternative for an inboard motor



Steerable PODs

320 degrees propulsive power for ultimate maneuverability

1

Entry level -
Steerable POD

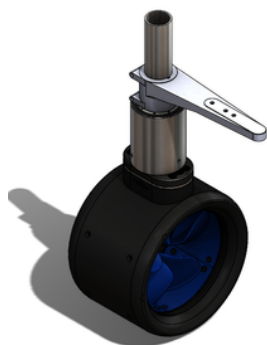

2

Steerable POD



Outboards

Different outboard solutions for your application

1

Entry level -
outboard



2

Steerable
outboard



Bow thrusters

Standard thruster

The best solution for continuous running times



Thruster tunnel set

A strong stainless steel provides a robust solution for bow thrusters

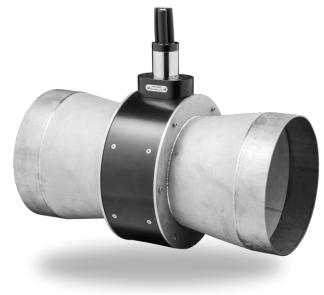

Bow thruster box

The bow thruster box makes it easy to access the motor

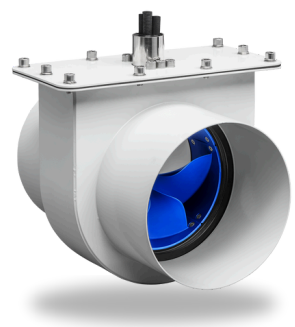



POD

The better alternative for an inboard motor

Characteristics



Electric propulsion



Minimized components



Low in maintenance



One day installation



Keyswitch included



Electric or hybrid

Integration



New build or refit



Custom made projects



Specs

	POD 0.5	POD 3	POD 5	POD 8	POD 11
Power (kW)*	0.5	3.0	5.0	8.0	11.0
Nominal voltage (V)	48	24 or 48	24 or 48	48	48
Weight (kg)	2.5	3.5	5	14	14
Static thrust (kgf)**	7	31	62	120	156
Salt water resistant	Yes	Yes	Yes	Yes	Yes
Controller included	Yes	Yes	Yes	Yes	Yes

*Motor power is depending on water conditions, usage and installation.

**Will be less for 24V installations.

Simplified but better

A Rim Drive motor is the most simplified motor design which is ever made. But don't confuse simplified with less powerful.

Forget all internal components which are needed for a classic inboard motor!

After finalizing the production process a Rim Drive POD motor is consisting out of only eight parts without any sealing needed.

The newest POD range motors are the most efficient and powerful solution for your medium speed application.

Choose a Rim Drive motor and use the additional space for more batteries to easily realize an 8-hour run time capability.

This is limiting the amount of service even further than any other electric motor.

Most efficient propulsion at cruise speed

97% of the applications doesn't require high speed capabilities. In general high efficiency is needed at cruise speed to guarantee a full-day of pleasure. Up to medium speeds a rim drive is the most efficient propulsion solution available in the market.

POD 5.0

4.0 km/h - 6:00 hr.

7.0 km/h - 4:00 hr.

10.0 km/h - 2:00 hr.

*1x 10kWh RDT battery.

POD 8.0

4.0 km/h - 6:00 hr.

7.0 km/h - 4:00 hr.

12.0 km/h - 2:00 hr.

*1x 10kWh RDT battery.

POD 11.0

5.0 km/h - 6:00 hr.

9.0 km/h - 4:00 hr.

13.0 km/h - 2:00 hr.

*2x 10kWh RDT battery.

POD 15.0

5.0 km/h - 6:00 hr.

9.0 km/h - 4:00 hr.

15.0 km/h - 2:00 hr.

*2x 10kWh RDT battery.

*Tested on a 8 meter, 2500kg sloop. For more reference project please contact sales@rimdrivetechology.nl

POD 15	POD 25	POD 30	POD 50
15.0	25.0	30.0	50.0
48	96	110	400 - 550
22	70	70	75
195	350	400	750
Yes	Yes	Yes	Yes
Yes	Yes	Yes	No



Entry level – Steerable POD

Maneuverability combined with unique rim drive motors

Characteristics



Electric propulsion



Minimized components



Low in maintenance



One day installation

Integration



New build or retrofit



Custom made projects

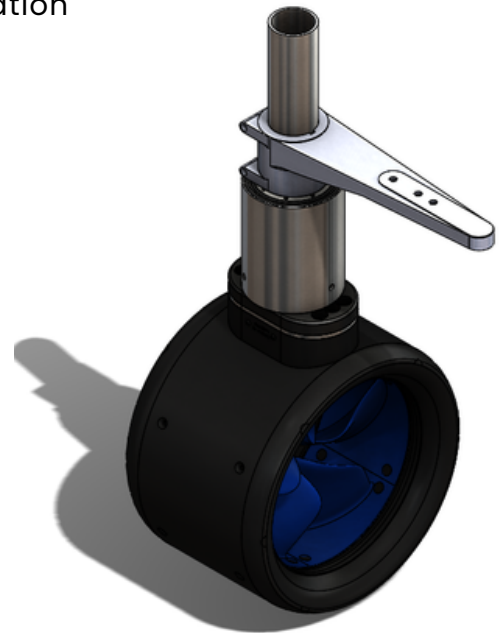

Specs

	EL. Steerable POD 3	EL. Steerable POD 5	EL. Steerable POD 8	EL. Steerable POD 11	EL. Steerable POD 15
Power (kW)*	3.0	5.0	8.0	11.0	15.0
Nominal voltage (V)	24 or 48	24 or 48	48	48	48
Weight (kg)	T.B.D.	T.B.D.	T.B.D.	T.B.D.	T.B.D.
Static thrust (kg)**	31	62	120	156	195
Salt water resistant	Yes	Yes	Yes	Yes	Yes
Controller included	Yes	Yes	Yes	Yes	Yes

*Motor power is depending on water conditions, usage and installation.

**Will be less for 24V installations.

Integration

Refit

- Interface standard compatible with industry standard steering cylinders and steering cables.

New installations

- Interface standard compatible with industry standard steering cylinders and steering cables.

Drop in replacement



You replace the rudder and sealing, install the motor through it and then secure the rudder arm. It can be connected to the current steering system.

EL. Steerable POD 25	EL. Steerable POD 30	EL. Steerable POD 50
25.0	30.0	50.0
96	110	400-550
T.B.D.	T.B.D.	T.B.D.
350	400	750
Yes	Yes	Yes
Yes	Yes	No



Steerable POD

Zero turn steering for ultimate maneuverability

Characteristics



Electric propulsion



Minimized components



Low in maintenance



One day installation



Joystick, steering wheel or CAN



Electric or hybrid

Integration



New build or retrofit



Custom made projects



Specs

	Steerable POD 3	Steerable POD 5	Steerable POD 8	Steerable POD 11	Steerable POD 15
Power (kW)*	3.0	5.0	8.0	11.0	15.0
Nominal voltage (V)	24 or 48	24 or 48	48	48	48
Weight (kg)	21.5	23	32	32	37
Static thrust (kgf)**	31	62	120	156	195
Salt water resistant	Yes	Yes	Yes	Yes	Yes
Controller included	Yes	Yes	Yes	Yes	Yes

*Motor power is depending on water conditions, usage and installation.

**Will be less for 24V installations.

Steering types

Joystick



With a joystick steering system, you can effortlessly and intuitively control your boat by simply moving the joystick in the desired direction. It provides precise maneuverability and allows easy turning.

CAN (digital)



The boat control is electronically managed through a Controller Area Network system. This advanced system utilizes digital signals to optimize engine control and steering behavior, resulting in accurate, responsive, and reliable boat steering.

Steering wheel



With a steering wheel control, you have a familiar and traditional way of steering your boat. The steering wheel offers a comfortable grip and makes it easy to adjust the boat's course with smooth and precise steering input.

The next evolution in boat control

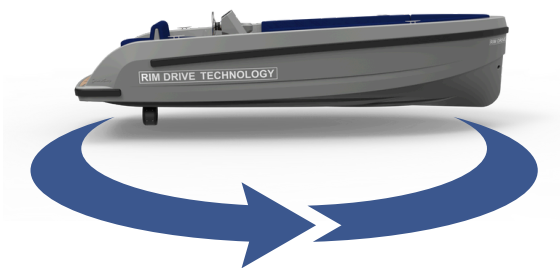

Zero turn

The steerable POD offers unparalleled manoeuverability and control, making navigating tight spaces and challenging water conditions effortless.

Steerable POD 25	Steerable POD 30	Steerable POD 50
25.0	30.0	50.0
96	110	400-550
110	110	110
350	400	750
Yes	Yes	Yes
Yes	Yes	No



Entry level – outboard

The perfect solution for operators who are looking for an affordable system

Characteristics



Electric propulsion



Integrated trim
Optional: electric trim



Low in maintenance



Integrated tilt
Optional: electric tilt



Integration



New build or refit



Custom made projects

Specs

	EL. Outboard 3	EL. Outboard 5	EL. Outboard 8	EL. Outboard 11	EL. Outboard 15
Power (kW)	3.0	5.0	8.0	11.0	15.0
Nominal voltage (V)	48	48	48	48	48
Weight (kg)	20	23	31	31	39
Static thrust (kg)**	30	60	120	155	195
Salt water resistant	Yes	Yes	Yes	Yes	Yes
Controller included	Yes	Yes	Yes	Yes	Yes

*Motor power is depending on water conditions, usage and installation.

Affordable solution

Our entry level outboard is the perfect solution for operators who are looking for an affordable solution with contains all functionalities they are looking for.

The motor controller will be delivered separately and can be installed in a compartment close to the motor.

The trim and tilt bracket is suitable for all standard steering cylinders available on the market. Therefore it is also a easy installable for refitting your boat!

The bracket contains five trimming positions to achieve the most efficient way of consuming your onboard power.





Steerable outboard

Zero turn steering as an outboard solution

Characteristics



Electric propulsion



Fixed trim
Optional: electric trim



Low in maintenance



Optional electric tilt



Joystick, steering wheel or CAN



Electric or hybrid



Integration



New build or refit



Custom made projects

Specs

	Steerable outboard 11	Steerable outboard 15.0
Power (kW)*	11.0	15.0
Nominal voltage (V)	48	48
Weight (kg)	T.B.D.	T.B.D.
Static thrust (kg)**	155	195
Salt water resistant	Yes	Yes
Controller included	Yes	Yes

*Motor power is depending on water conditions, usage and installation.

Optimal maneuverability

Our steerable outboard boasts an impressive 320-degree rotation and 360-degree propulsion, configurable to lower angles if needed. This function ensures optimal maneuverability

The steerable outboard supports remote operation. This means it can be controlled by your local service partner, and RDT technicians are able to provide remote support through adjustable settings.

Differences

Entry level & steerable outboard

	Entry level - outboard	Steerable outboard
Motor controller	External installed in motor room	Integrated in motor housing
Steering functionality	Hydraulic steering cylinder excluded in price	Electric steering motor integrated in motor
Price	Entry level, competitive pricing with other brands	Price based on functionalities, design and unique product
Maneuverability	Approximately 45 - 90 degrees	320 degrees, 360 propulsive power
Design	Easy, compact and functional	Elegance, compact and functional to every boat design
Installation	Very simple, everyone can do it	Requires more knowledge and skill.
Trim	Manual trim	Hydraulic trim



Standard thruster

The best solution for continuous running times

Characteristics



Electric propulsion



Extreme power



Low in maintenance

Integration



New build or retrofit



Custom made projects



Specs

	Standard thruster 0.5	Standard thruster 3	Standard thruster 5	Standard thruster 8	Standard thruster 11
Power (kW)*	0.5	3.0	5.0	8.0	11.0
Nominal voltage (V)	48	24 or 48	24 or 48	48	48
Weight (kg)	2.5	3.5	5	14	14
Static thrust (kg)**	5.5	23 / 25	50 / 55	120	140
Salt water resistant	Yes	Yes	Yes	Yes	Yes
Controller included	Yes	Yes	Yes	Yes	Yes

*Motor power is depending on water conditions, usage and installation.

**Will be less for 24V installations.

Features

Our standard thruster is the most quiet bow thruster on the market. The bow thruster is efficient and also available as a stern thruster.

The standard bow thruster is extremely compact which makes it possible to place it further in the nose of the boat.

Compability per boat length (m)

Choosing the right electric motor for a boat is crucial for optimal performance and efficiency on the water. In the table below, the compatibility per boat length is shown.

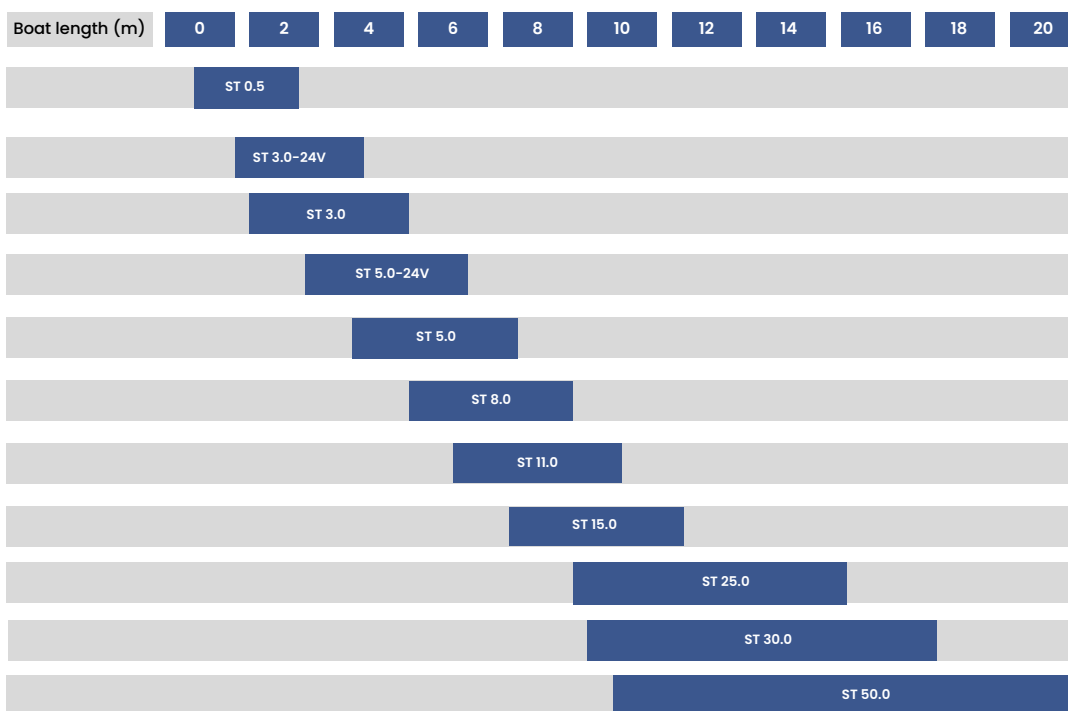

Standard thruster 15	Standard thruster 25	Standard thruster 30	Standard thruster 50
15.0	25.0	30.0	50.0
48	96	110 or 400	550
21	70	70	73
175	300	350	675
Yes	Yes	Yes	Yes
Yes	Yes	Yes	No



Thruster tunnel set

A strong stainless steel provides a robust solution for bow thrusters

Characteristics



Electric propulsion



Extreme power



Low in maintenance



Tunnel installation

Integration



New build or retrofit



Custom made projects

Specs

	Thruster tunnel set 3	Thruster tunnel set 5	Thruster tunnel set 8	Thruster tunnel set 11
Diameter tube (mm)	114.3	168.2	256	256
Weight (kg)	5.5	8	25	25
Material*	Stainless steel	Stainless steel	Stainless steel	Stainless steel

*On request, other materials are also available such as steel, aluminium and glass fiber.

Features

The tunnel set is easy to integrate into the boat. The bow thruster tunnels are easy to install due to the various mounting options

The tunnel set is specially designed for difficult conditions where the bow thruster remains protected.

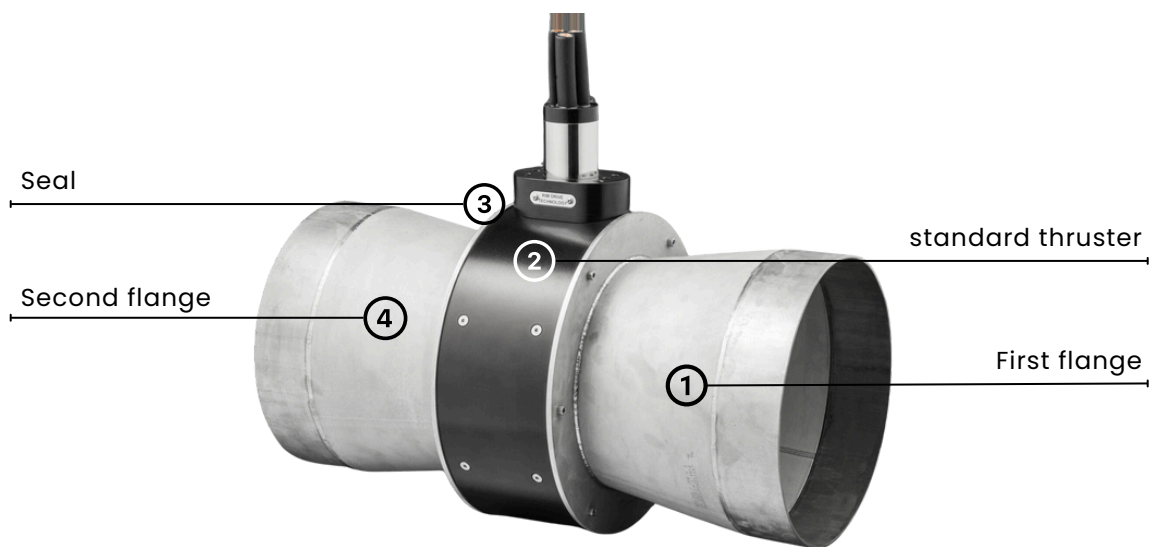

Thruster tunnel set 15	Thruster tunnel set 25	Thruster tunnel set 30	Thruster tunnel set 50
256	355.6	355.6	355.6
32	100	100	103
Stainless steel	Stainless steel	Stainless steel	Stainless steel



Bow thruster box

The bow thruster box makes it easy to access the motor

Characteristics



Electric propulsion



Extreme power



Low in maintenance



Closed box installation

Integration



New build or retrofit



Custom made projects



Specs

	Bow thruster box 3	Bow thruster box 5	Bow thruster box 8	Bow thruster box 11	Bow thruster box 15
Tunnel diameter (mm)	086	133	212	212	212
Weight (kg)	5.5	7	16	16	23
Material*	Stainless steel	Stainless steel	Stainless steel	Stainless steel	Stainless steel

*On request, other materials are also available such as steel, aluminium and glass fiber.

Features

This motor boasts easy removal from its box, even when above the waterline, avoiding the need to take the boat out of water.

Its standardized tunnels allow straightforward installation ensuring waterproof and adequate cooling for the bow thruster.

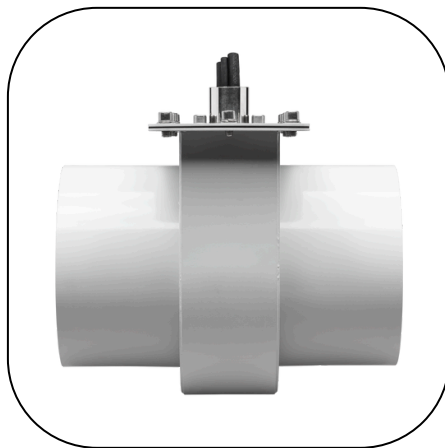
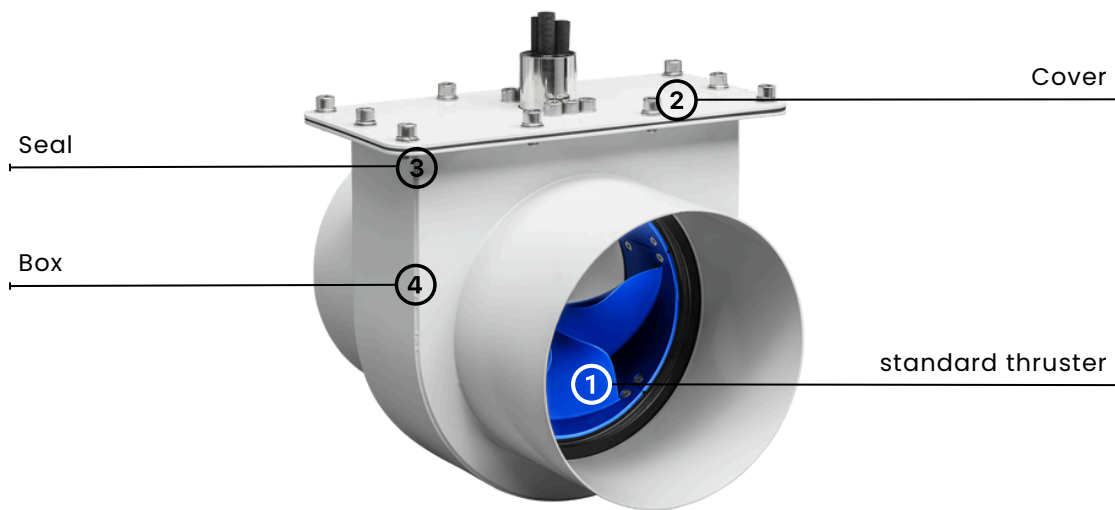

System functionalities

Our system features improve the experience, efficiency and safety for the user. We offer the following additional functionalities: steering sensitivity mode, side-shift parking mode, zero turn steering and magnetic compass.

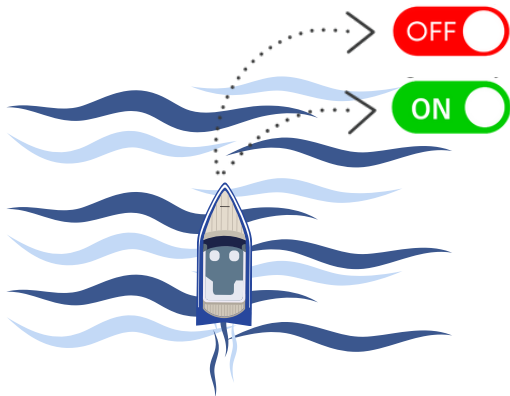

Steering sensitivity mode

With this function the sensitivity of the throttle can be determined by a single button. This function makes it possible to steer very accurate in smaller spaces.

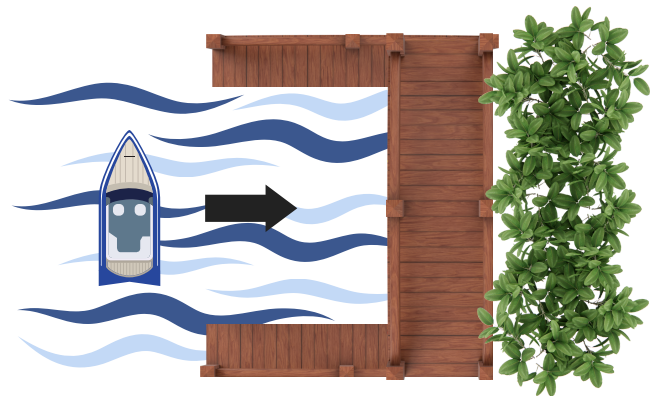

Side- shift parking mode

A parking function on a boat is crucial when docking. It provides precise control and stability, allowing for safe and easy boat parking.

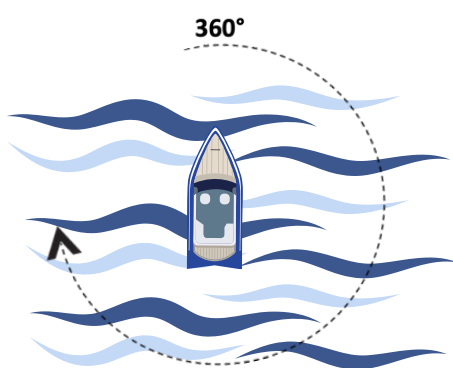

Zero Turn steering

Differential steering makes it possible to rotate on your position with two fixed pods. We have realized an algorithm which calculates which motor should run in forward or reverse mode and at which RPM.

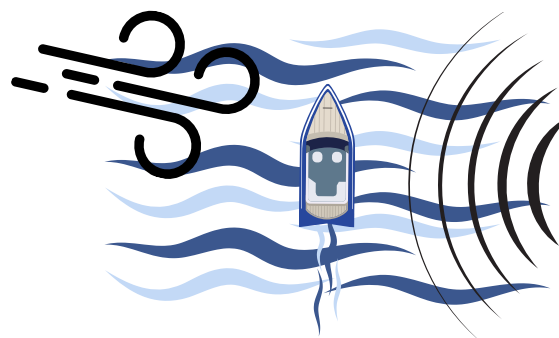

Magnetic compass

This feature corrects currents and wind influences, making it possible to sail a straight course for a long time. It minimizes deviations and provides a relaxed and stable sailing experience.



Batteries and chargers

12V batteries

12V 60Ah



12V 100Ah



12V 200Ah



48V batteries

48V 60Ah



48V 100Ah



48V 200Ah



Chargers

48V 2000W



48V 3300W

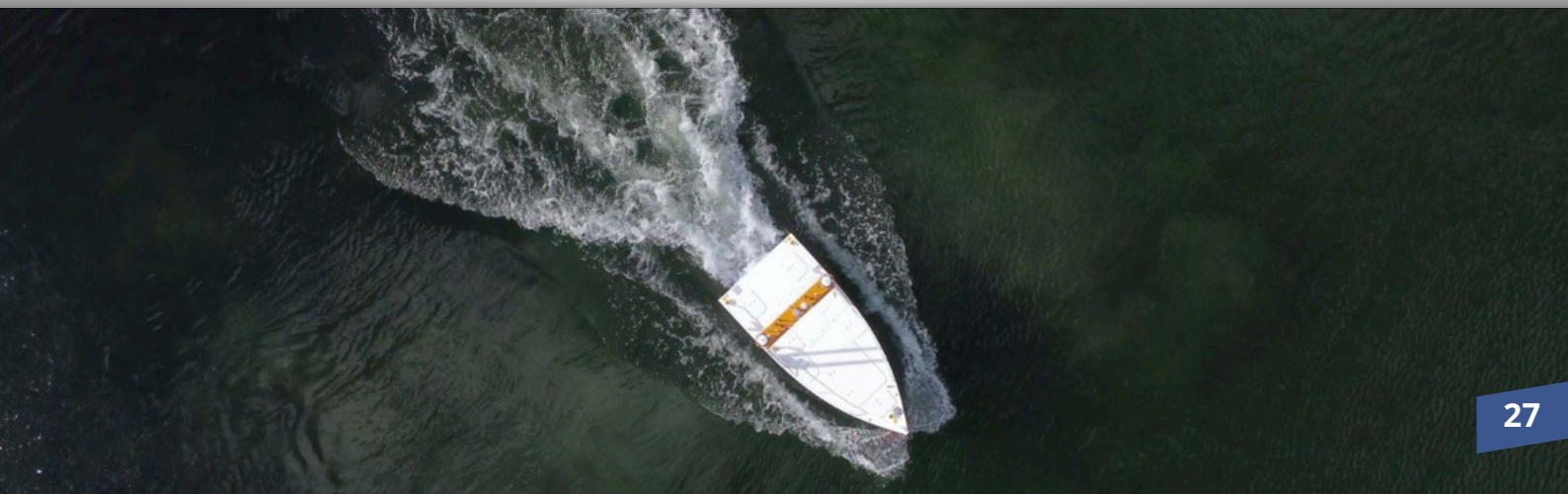

Our unique batteries

The high energy density, combined with no maintenance costs and affordable pricing makes these batteries the perfect candidate for those who wish to be powered electric. There are multiple technical advantages of our batteries that make a Rim Drive Technology battery a pleasure to use.

Why a Rim Drive battery?



A Rim Drive battery has a high **energy density**.

Our **lightweight** and **powerful** batteries use the **latest technology** for incredible weight savings.

Due to the **minimal dimensions**, the battery can be used for many applications.

Our batteries are **maintenance-free**, so no service attention is required.

To provide the best customer experience, our batteries work **efficiently** with all our products.



Batteries

The best solution for full day operation

Characteristics



Integrated BMS



High energy density



No maintenance



Affordable pricing

Type

	12V 60Ah	12V 100Ah	12V 200Ah	48V 60Ah*	48V 100Ah*	48V 200Ah*
Nominal voltage	12.8V	12.8V	12.8V	51.2V	51.2V	51.2V
Nominal capacity	60Ah	100Ah	200Ah	60Ah	100Ah	200Ah

Dimensions

	12V 60Ah	12V 100Ah	12V 200Ah	48V 60Ah	48V 100Ah	48V 200Ah
Weight (kg)	7.6	12.7	28.1	30	50	75
Dimensions (LxWxH)	26x17x22 cm	33x17x23 cm	52x27x23 cm	34x33x26 cm	51x35x26 cm	60x42x24 cm

Temperatures

Environment	Details	Minimum	Maximum
Operating temperature	Charge	0°C	45°C
	Discharge	-20°C	65°C
Storage temperature	1 month	-20°C	60°C
	3 months	-20°C	45°C
	12 months	-20°C	20°C

Certification standards

EN IEC 61000-6 1:2019
EN 61000-6 3:2007 + A1:2011 + AC:2020
EN IEC 61000-3-2:2019
EN 6100-3-3:2013 + A1:2019
EN-IEC 62620:2015
EN-IEC 62619:2022

*Optional: notified body certification

New generation

All batteries have an integrated BMS. The batteries can be connected up to 4 pieces in parallel.

With our new generation of LiFePO4 batteries, we aim to make the use of batteries both easy and affordable.

In case you want to have high voltage batteries, please contact our sales team.

Battery specifications

	12V 60Ah	12V 100Ah	12V 200Ah
Max. continues charge current	30A	50A	100A
Max. continues discharge current	60A	100A	100A
Max. instantaneous discharge current	120A	200A	200A
Maximum charge voltage	14.6V	14.6V	14.6V
Dischrage cut-off voltage	10V	10V	10V

All batteries are supplied with handles.

Battery specifications

	48V 60Ah	48V 100Ah	48V 200Ah
Max. continues charge current	30A	50A	100A
Max. continues discharge current	120A	125A	200A
Maximum charge voltage	58.4V	58.4V	58.4V
Dischrage cut-off voltage	35.2V	35.2V	35.2V

All batteries are supplied with handles.

Chargers

Chargers to keep you connected and powered up

Characteristics



High efficiency



Low weight



IP67 sealed



Compact design

Specs

	2000W	3300W
Nominal voltage	48V	48V
Max. charge voltage (V)	58,4	58,4
Max. charge current (A)	35	50
Weight (kg)	4,5	6
Dimensions (mm)	282x181x98	350x188x99
IP-rating	67	67

Accessories

Throttle controls

Single- Top



Single- Side



Double- Standard



Thruster control



Steerable POD joystick



Smart solutions

Smart steering system



Displays

Display 5"



Display 7"



Display 9"





Throttle controls

Our unique throttle control for ultimate compatibility

All our throttle controls are lightweight, and easy to use. Through intensive testing, a reliable throttle has been created that can guarantee the safety of the user on the water.

Characteristics



Easy to use



Saltwater resistant



Interchangeable handle design



Compact design

Specs

	Single- Top	Single- Side	Double- Standard
Technology	Hall effect sensor	Hall effect sensor	Hall effect sensor
Rated voltage	5V	5V	5V
Output voltage	0.8V - 4.2V	0.8V - 4.2V	0.8V - 4.2V
Operating temperature range	-25°C to +55°C	-25°C to +55°C	-25°C to +55°C
Storage temperature range	-40°C to +85°C	-40°C to +85°C	-40°C to +85°C
Mechanical angle	±90	±90	±90
Protection class	IP68	IP68	IP68
Weight (kg)	0.6	0.4	2



Thruster control	Steerable POD joystick
With push button	Voltage range 0.5V - 4.5V
Straight lever	Straight lever
Quick-fit fastener	Quick-fit fastener
Switching voltage 5V	Switching voltage 5V

Smart solutions

Without rudders and additional steering mechanism

Steering with twin motors without rudders and additional steering mechanism. Rotation on location. A magnetic compass with LED indicator. A speed button with LED indicator and a joystick with algorithm to control twin motor system.

Unique functions

High speed selector

With this feature, the Rim Drive motor delivers full power, enabling smooth, long-distance propulsion, while the steering motor responds with reduced sensitivity for easier control.

Cruise control selector

The motor will automatically corrects the effect of wind and current based on a compass signal.

Smart steering system

Magnetic compass

Speed function

Joystick CAN controller

12V power supply unit





Displays

Provides the right information at the right time

All our displays have a waterproof design with an extremely bright display. The display shows important information such as estimated battery life, battery charge status, power consumption, global waterway maps and many more.

Characteristics



Intelligent warnings



Water- and dustproof



Bright display



Advanced multi-touch

Specs

	Display 5"	Display 7"	Display 9"
Voltage	8-28V DC	8-28V DC	8-28V DC
Operating temperature	-20 to 60°C	-20 to 60°C	-20 to 60°C
Consumption	440mA 12V	650mA 12V	800mA 12V
IP rating	IPX6	IPX6	IPX6
Connection	WIFI	WIFI	WIFI
GPS	Yes	Yes	Yes
Multi-language	Yes	Yes	Yes
Alarms	Visual and audible	Visual and audible	Visual and audible
Auto-on	Yes	Yes	Yes



Intelligent warnings



Compact touch



Global waterway maps

RIM DRIVE TECHNOLOGY



**Uncompromised
Electric Motors**

www.rimdrivetechology.nl

+31 (0) 85 482 48 55

Info@rimdrivetechology.nl