

RIM DRIVE TECHNOLOGY



User manual TH086-S-24V The Netherlands

No rights can be derived from the contents of this document in any way,
nor can any claims be laid to this.

Changes

Version	Date	Changes
1	4-6-2021	Original

Foreword

Dear Customer,

We are delighted by the choice for our products. The TH086 system delivers high-performance by using rim drive technology and is highly efficient. It has been designed and manufactured with an eye on convenience, environment friendly character, user-friendliness and safety. Before shipment, every motor is tested extensively by our engineers.

Please take the time to read this operating manual carefully as to ensure safe and proper use of the motor. It is always our intention to improve RDT products, for any comments please do not hesitate to contact us.

Please feel free to contact us with any product inquiries. We wish you all the best with our products.

Rim Drive Technology

Declaration of Conformity

Company name manufacturer	Rim Drive Technology
Company address manufacturer	Wanraaij 33 6673 DM Andelst The Netherlands
Product type	TH086-S-24V

Content

Changes	2
Foreword	3
Declaration of Conformity	4
1. General	7
1.1 Using this user manual	7
1.2 Pictograms.....	7
1.3 Copyright.....	7
1.4 Ensure	8
1.5 Manufacturer details.....	8
2. Security	9
2.1 Appropriate use.....	9
2.2 Requirements for operators	9
2.3 Safety.....	10
2.4 Maintenance/fault removal	10
3. Technical data.....	11
3.1 General data.....	11
4. Mounting	12
5. Description.....	13
5.1 General.....	13
5.2 Construction	13
6. Installation	14
6.1 Hardware.....	14
6.1.1 Motor controller.....	14
6.1.2 Fuses.....	14
6.2 Software	14
6.3 Batteries	14
7. Operation	15
7.1 Preparation	15
7.2 Operation	15
7.3 Stop operation.....	15
7.4 Use frequently	15
8. Maintenance & cleaning.....	16
8.1 Maintenance	16
8.1.1 Replacement parts.....	17

- 8.1.2 Corrosion protection.....17
- 8.2 Cleaning17
- 8.3 Dismounting.....17
- 9. Disorders18
- 10. Disposal and environment19
 - 10.1 Disposal of waste electrical and electronic equipment.....19
 - 10.2 Disposal of batteries19
- 11. General conditions for warranty20
 - 11.1 Warranty and liability.....20
 - 11.2 Scope of warranty20
 - 11.3 Warranty process21
 - 11.4 Shipment.....21

1. General

1.1 Using this user manual

Every person who is operating, servicing, maintaining or using the RDT rim drive must have read and understood this manual in detail. The manual provides important instructions for the safe and proper use of the RDT rim drive. After reading this user manual the owner/operator should have an understanding on how to

- Install the product
- Operate the product
- Avoid risks/hazards

Always store this manual close to the RDT rim drive. We advise to store the manual in a waterproof sealing.

The illustrations in this manual are for illustrative purposes only and are not relevant to the design details of the RDT rim drive.

1.2 Pictograms

The following pictograms are used in this manual:



Dangerous situation. If this warning is ignored, personal injury up to death or serious damage to the RDT rim drive may result.



Danger due to electric current. The work may only be carried out by a trained electrician



Danger of possible damage to the environment.



Note of useful advice on how to use the RDT rim drive.

1.3 Copyright

This is a confidential user manual. Only persons who have been authorized on written document by Rim Drive Technology. All documents are protected within the meaning of the Copy-right Act.

Disclosure and duplication of documents, including extracts, exploitation and communication of their contents are not permitted. Violations are punishable and oblige to pay damages. We reserve all rights of exercise of industrial property rights.

1.4 Ensure

For safe and pleasant operation and use of the rim drive, it is recommended to read this manual in full before installing or commissioning the RDT rim drive. The manufacturer is not liable for damages or improper functioning of the RDT rim drive as a result from failing to adhere to the operating instructions.

Additionally, please read/check the national regulations before the use of the RDT rim drive.

The warranty expires, for example, in the case of:

- Usage for another application than intended by the manufacturer or beyond the applications as described within this manual.
- Installation not in accordance with the manual
- Use of non-original spare parts and complementary products
- Maintenance/servicing by a non-authorized persons/company.
- Operating RDT rim drive outside the water
- Damage caused by journeys through overgrown waters (e.g. reeds) or too shallow waters.

1.5 Manufacturer details

Rim Drive Technology BV

Wanraaij 33
6673 DM
Andelst
The Netherlands

+31 (0) 85 482 48 55
info@rimdrivetechology.nl
www.rimdrivetechology.nl

2. Security

2.1 Appropriate use

The RDT rim drive is to be used as a propulsor for leisure boat applications. Any other type of application is not allowed without written permission by RDT.

Only power sources which have been approved by RDT should be used in combination with the RDT products.



Danger of destruction! When operating outside the water the RDT rim drive can be destroyed. Operate the RDT rim drive only in water.

The intended use also includes people who are servicing/maintaining or operating the RDT have read and understood this user manual. All procedures described in this user manual must be followed.

The manufacturer is not responsible for damages resulting from operation in a way which is not in accordance with this manual. The risk is exclusively for the user/operator.

2.2 Requirements for operators

Only persons who have the right licenses (according to national law) may use the RDT rim drive as a boat drive.



The required qualification can be found in the applicable national regulations and laws of the country in which the boat is used.

Repair work, follow-up and maintenance/service may only be carried out by persons with the appropriate training and qualifications.

Persons under the influence of drugs, alcohol or reacting drugs are not allowed to carry out work on the RDT rim drive or to operate it.

2.3 Safety

In addition to the information in this manual, observe the general legal and other binding regulations for accident prevention and environmental protection as well as basic health and safety regulations.

- Check if the RDT rim drive is in perfect condition before operating
- Turn on the RDT rim drive only when it is placed completely in water. This is the only way to avoid damage to the RDT rim drive.
- Never remove or change safety devices.
- Before use always inspect the RDT rim drive for (external) recognizable damage and defects. If any damage and/or defects are recognized they must be reported immediately to a RDT qualified service partner.
- Use only professional and qualified maintenance tools.
- After repairs/maintenance, reattach all dismantled protective devices and ensure proper functioning.
- Every operator is responsible to make sure that the RDT rim drive is only operated in perfect/non-damaged condition and that all applicable safety requirements and regulations are complied with.
- Never allow the boat to which the rim drive is mounted to be towed when the system is turned off.

2.4 Maintenance/fault removal

Check the deadlines for regular inspections specified in the user manual.

Use only the professional/qualified tools for maintenance/fault removal.



Danger from electric current! Incorrect work on the power supply may result in damage to the RDT rim drive. Work on the electrical equipment of the RDT rim drive may only be carried out by a certified electrician.

3. Technical data

3.1 General data

Model	Thruster
Type	TH086-S-24V
Input voltage	24V
Nominal power	3kW
Maximum RPM	4.000
Maximum temperature	85°C
Temperature sensor	PT1000
Maximum depth	50 meter, 3.000 meter on request

4. Mounting

Use the two holes pattern on the mounting socket when mounting the motor.

- Only mount the motor to a strong and stable mounting bracket.
- See drawing below for mounting holes pattern (6x M10). At least 4 holes should be used.
- Use Loctite 577 on the thread of the M10 stud bolts when mounting the motor.
- The material of the bolts has to be AISI Type 316L stainless steel and with the help of a torque wrench (18 Nm) screw in the bolts.
- The bolts must be mounted so that the thread is completely filled,

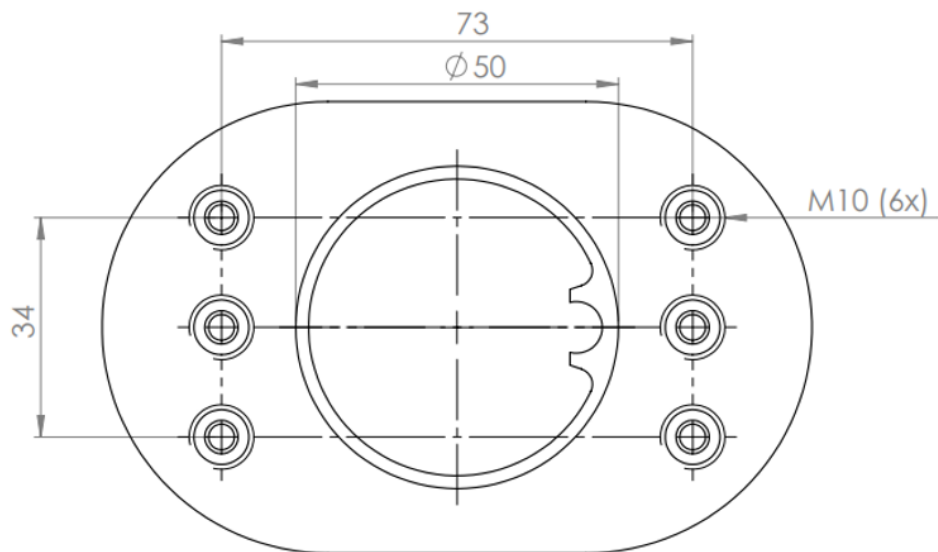

Danger of broken motor! When the motor is not installed in the right way there is risk for a broken motor.

5. Description

5.1 General

The RDT rim drive is a propulsion system for leisure boats. The installation location can be chosen by the client as long as it can be mounted securely and in accordance with this manual. In case of any questions, please contact a RDT or a RDT qualified service center.

The rim drives have been designed in such a way that the power supply can be provided by generators or battery packs.

5.2 Construction

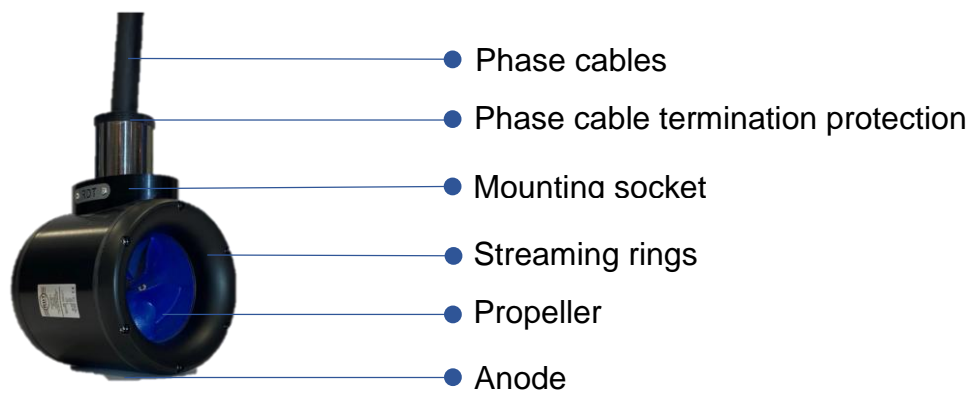

The connection of the RDT rim drive to the hull is depending on the location of connection.

A sticker is connected to each motor, it records the key data as per the EC machinery directive 2006/42/EC.

6. Installation

6.1 Hardware

For the installation always refer to a professional and trained company. The motor controller, batteries, throttle controls and other products shall only be installed as described by Rim Drive Technology.

No client, installation company, dealer or any other person/company is allowed to make any changes to the hardware/software.

All safety equipment like kill switches, fuses, relays, other type of safety products should be installed by a professional and trained company according regulation/law for the country within which the products are used.

When verifying the correct operation of the motor, ensure all DC connections are checked immediately after reaching full power. When performing this check directly after full power is applied, all connections should not be warm to the touch. If connections are hot to the touch, please reinstall the DC connections.

After 10 and after 50 hours of running the motor the mounting socket bolts have to be checked, see chapter 4.

6.1.1 Motor controller

Depending on the choice of motor controller, a wiring schematic should be followed. Always contact RDT for the manual of the motor controller. The motor controller should be connected using shielded cables which are preferably located in stainless steel or aluminium tubing.

6.1.2 Fuses

To ensure a safe system several fuse(s) have to be installed. RDT is not responsible for damage occurred by fuses which were not delivered by RDT.

6.2 Software

Rim Drive Technology will provide software which is developed for the specified configuration. Nobody is allowed to make any changes to the software, except Rim Drive Technology.

6.3 Batteries

The motors could additionally be used as a generator. Make sure that the used configuration is suitable for this purpose.

7. Operation

7.1 Preparation

Ensure the following preparations have been carried out before operating the RDT products.

- Unplug the cable/plug from the power supply.
- Store the charging cable in a way which as to prevent damage or tripping.
- Check the remaining capacity of the batteries.



Do not put the RDT rim drive into operation if the remaining battery capacity is < 20%

7.2 Operation

Ensure the following preparations have been carried out before operating:

- Turn on the power supply for the RDT rim drive.
- Ensure the motor can be put forwards and backwards without noise etc.
- Regularly check the remaining battery capacity during operation. Otherwise there is a risk of having no propulsion.

7.3 Stop operation

Ensure the following actions have been carried out when stopping the use of the RDT rim drive:

- Turn off the power supply for the RDT rim drive.
- Connect the charging cable to the charger.
- Make sure that the charging cables are placed in a safe way as to prevent tripping or accidental damage.



Lay down the charging cable as to prevent damage.

7.4 Use frequently

The motor has to be used for a minimum of five hours every three months to make sure the bearings will not seize up.

8. Maintenance & cleaning

8.1 Maintenance

Have the RDT rim drive checked at least once a year by Rim Drive Technology or by an authorized specialist to check for perfect condition. If damage is discovered, it must be rectified immediately by a RDT service partner before operating. Do not use the RDT product when it is damaged.



Danger of destruction! Maintenance should only be performed by authorized personal/ service centers. Otherwise, errors may occur which can lead to the destruction of the rim drive. Rim Drive Technology accepts no liability for damages caused by improper maintenance.

Maintenance level	Executor	Working hours	Time
Maintenance level 1	Client	5 hours	Every run
Maintenance level 2	Client	100 hours	One year
Maintenance level 3	RDT Service partner	1.000 hours	Five years

Service task	Level 1	Level 2	Level 3
Test functionality	Propeller turns forward Propeller turns reverse Motor is reacting fast		
Cable connections		Check for damage Visual check Check connectors	
Batteries and cables		Visual check of cables Visual check of connectors Visual check of connections	
Anode		Replacement	
Mechanical connection to hull		Test and repair if necessary	
Waterproofness			Visual check of complete motor
Full product test			Control propeller quality

*The client is responsible to contact a RDT authorized service center for maintenance level 3.

8.1.1 Replacement parts

For information on spare parts and the installation of these parts, contact Rim Drive Technology or an authorized Service Partner.

8.1.2 Corrosion protection

A high level of corrosion resistance is ensured by the design of the products and with the selection of the materials. All materials are classified as sea water resistant materials.

To reduce the chance of corrosion:

- Check the anode latest every 6 months. Change the anode every 12 months or after >50% of anode has been destroyed by environment.
- Regularly apply a suitable contact spray (e.g. Wet protect) to cable contacts, data sockets, and data plugs.
- The use of anti-fouling agent is forbidden.
- Only mount original RDT anodes to the rim drive motor. Otherwise no guarantees can be given.

8.2 Cleaning

Before starting turn off the power supply, as to prevent accidental activation during the cleaning process.



Injury! When the power supply is switched on, the rim drive may cause injuries to the limbs when cleaning the RDT rim drive.

The cleaning intervals depend on the area of application and the number of operating hours. At least, the rim drive must be cleaned once a year in fresh water.

In case of contaminated, salt water or with frequent use of the rim drive; the interval between cleaning should be shortened.



Only use fresh water for cleaning.

8.3 Dismounting

The client is not allowed to dismount, remove or disassemble any parts from the products. Examples of activities which are not allowed:

- Removal of mounting rings
- Removal of rotor housing
- Removal of cables
- Removal of mounting socket

9. Disorders

Make sure that the power supply is switched off and is secured against activation.



Injury! When the power supply is switched on the rim drive may cause injuries to the user.

Disorder	Possible cause	Fix
The rim drive is not running.	The main switch is not turned on.	Turn on the main switch.
	The batteries are empty.	Charge the batteries.
	The propeller is blocked.	Check if the propeller is damaged.
	Connection/Wiring is not correct/bad.	Check wiring and connections.
The batteries are not charging.	The motor controller gives an error.	Restart the system
	The plug from the charging cable is not properly plugged into the land-side power supply.	Insert the plug correctly into the land-side power supply.
	The land-side power supply is switched off.	Turn on the land-side power supply.
	The batteries are defect.	Replace the defect batteries.

10. Disposal and environment

10.1 Disposal of waste electrical and electronic equipment

For customers in EU countries

RDT permits all clients to follow the European Directive 2012/19/EU relating to Waste Electrical and Electronic Equipment – WEEE, and to the corresponding national laws. The WEEE Directive forms the basis for handling waste electrical equipment across the whole of the EU. The RDT system is marked with the symbol of a crossed-out rubbish bin. Waste electrical and electronic equipment must not be disposed of as normal household waste, because this could allow entry of pollutants to the environment which have effects injurious to health on humans, animals, and plants, and which build up in the food chain and in the environment. In addition, valuable raw materials are lost in this way. Please therefore direct all waste equipment for separate collection in an environmentally friendly way.



For customers in other countries

RDT permits all clients to follow the European directive 2012/19/EU regarding waste electrical and electronic equipment. We recommend that the system is not discarded as normal household waste, rather this should be disposed of via separate collection in an environmentally friendly way. The applicable national laws may also prescribe this. Therefore, please ensure appropriate disposal of the system as per the regulations which apply in the country within which the rim drive is used.

10.2 Disposal of batteries

Remove spent batteries immediately, and comply with the following specific disposal information relating to batteries or battery systems:

For customers in EU countries

RDT permits all clients to follow the European directive 2006/66/EC regarding (spent) batteries, as well as to the corresponding national laws. Here the Battery Directive forms the basis for handling batteries throughout the EU. Our batteries are marked with the symbol of a crossed-out rubbish bin. Spent batteries must not be disposed of as normal household waste, because this could allow pollutants to enter the environment which could have effects injurious to health on humans, animals, and plants, and which build up in the food chain and in the environment. In addition, valuable raw materials are lost in this way. Please therefore dispose of the spent batteries exclusively via specially set-up collection points, the dealer, or the manufacturer. There is no charge for handing them in.

For customers in other countries

RDT permits all clients to follow the European directive 2006/66/EC regarding (spent) batteries. The batteries are marked with the symbol of a crossed-out rubbish bin. We recommend that the batteries are not discarded as normal household waste, rather this should be disposed of via separate collection. Your national laws may also prescribe this. Therefore, please ensure appropriate disposal of the batteries as per the regulations which apply in the country within which the rim drive is used.

11. General conditions for warranty

11.1 Warranty and liability

The statutory warranty runs for and includes all components of the RDT system. The client needs to activate the warranty within 30 days after delivery via our website: www.rimdrivetechology.nl

The warranty period starts from the day of delivery of the RDT system to the end customer.

11.2 Scope of warranty

Rim Drive Technology, Wanraaij 33, 6673 DM, Andelst guarantees the end customer of a RDT system, the product is free from material and manufacturing defects during the period of coverage defined below. Rim Drive Technology will indemnify the end customer for the costs of correction of a material or manufacturing defect. This indemnification obligation does not apply to any incidental costs caused by a warranty case or to any other financial detriment (e.g. costs for towing, telecommunication, accommodation, subsistence, loss of use, lost time, etc.).

The warranty terminates two years from the day of handover of the product to the end customer. Products used - even temporarily - for professional or official purposes are excluded from the two-year warranty. For these uses, the statutory warranty applies. The guarantee claim expires six months after the discovery of the defect.

Rim Drive Technology decides whether defective parts are repaired or replaced. Distributors and dealers who carry out repair work on Rim Drive Technology motors have no power to make legally binding statements on behalf of Rim Drive Technology.

Wearing parts and routine maintenance are excluded from the warranty.

Rim Drive Technology has the right to refuse warranty claims if:

- The warranty was not submitted correctly (especially failure to make contact before dispatching goods under complaint, absence of a fully completed warranty form and of proof of purchase; see warranty process).
- The product has been used in a manner contrary to instructions.
- The safety, operating, and care information in the instructions were not followed.
- Prescribed maintenance intervals were not complied with and documented.
- The purchased item was in any way converted, modified, or equipped with parts or accessory items which are not expressly authorized by Rim Drive Technology or which do not form part of recommended equipment.
- Previous maintenance or repairs were undertaken by companies not authorized by Rim Drive Technology, or parts other than original replacement parts were used. This applies unless the end customer can prove that the circumstances resulting in the refusal of the warranty claim have not encouraged the progress of the defect.
- The product has been used for other applications as described.

In addition to the claims arising from this warranty, the end customer has statutory warranty rights arising from his purchase contract with the relevant dealer; these are not restricted by this warranty.

11.3 Warranty process

It is a prerequisite that the warranty process described below is followed for the fulfilment of warranty claims.

For the problem-free handling of warranty cases, we request that the following instructions are complied with:

- In the event of a claim, please contact Rim Drive Technology. RDT will provide a return number (RMA Number).
- Should it be necessary to transport products to Rim Drive Technology premises, please note that inappropriate transport is not covered by guarantee or warranty.

For queries regarding the warranty process, we can be contacted by means of the details given in this manual.

11.4 Shipment

The client is responsible for shipment, costs and any damage or loss which are related to this shipment.